



### TE speedy

Dimming via leading-edge and trailing-edge phase dimmers

#### Product description

- Compact dimensions
- Short-circuit shutdown feature with automatic restart
- Overtemperature and overload protection with power regulation
- Large connection compartment
- Double assignment of the terminal possible
- Cage clamp terminals for rigid and flexible wires
- Double terminals on the secondary side
- Rapid installation of cable clamp and terminal cover, no tool required
- Casing: polycarbonate, dark blue/white
- Not suitable for operation with MR16 LED bulbs

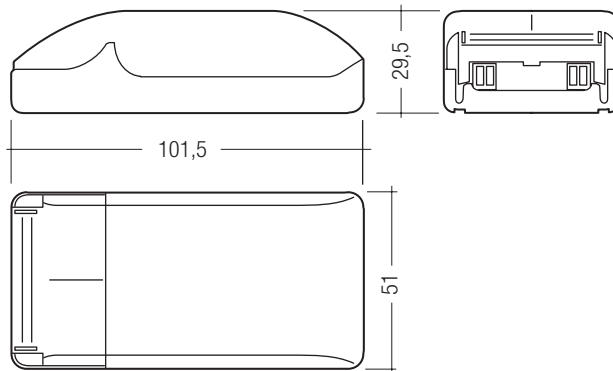

#### Technical data

Mains voltage range	230 – 240 V
Mains frequency	50 / 60 Hz
Dimming	Leading-edge and trailing-edge phase control
Soft-start	< 1 s
$\lambda$	> 0.95
Efficiency	> 93 %
Max. cable length secondary	2 m
Protection class	II
Type of protection	IP20

#### Ordering data

Type	Article number	Packaging carton	Packaging pallet	Weight per pc.
TE-0050 C101	24034855	20 pc(s).	1,000 pc(s).	0.100 kg
TE-0070 C101	24034868	20 pc(s).	1,000 pc(s).	0.106 kg
TE-0105 C101	24034874	20 pc(s).	1,000 pc(s).	0.120 kg

#### Specific technical data

Type	Dimensions L x W x H	Lamp power	Rated current (at 230 V, 50 Hz)	Secondary voltage 230 V	Secondary voltage 240 V	Operating frequency	Ambient temperature $t_a$	Max. casing temperature	Secondary terminal
TE-0050 C101	101.5 x 51 x 29.5 mm	20 – 50 VA	0.215 A	11.5 V	11.7 V	60 kHz	-20 ... +50 °C	85 °C	4-pin
TE-0070 C101	101.5 x 51 x 29.5 mm	20 – 70 VA	0.300 A	11.5 V	11.7 V	55 kHz	-20 ... +50 °C	85 °C	4-pin
TE-0105 C101	101.5 x 51 x 29.5 mm	35 – 105 VA	0.450 A	11.5 V	11.7 V	40 kHz	-20 ... +45 °C	85 °C	4-pin

## Installation instructions

### Wiring type and cross section

The wiring can be in stranded wires with ferrules or solid. For perfect function of the cage clamp terminals the strip length should be 4 – 5 mm for the input terminal.

The max. torque at the clamping screw (M3) is 0.2 Nm.

### Input terminal (D2)

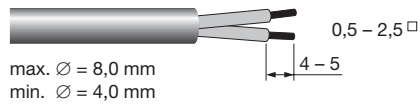

### Output terminal (D1)

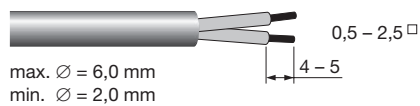

To get a proper working strain relief it is recommended that the cable jacket diameter of the side D2 is compared to the side D1 terminal according to the value table. (This can vary if the used cable jacket material varies from side D2 to D1 in pinching property).

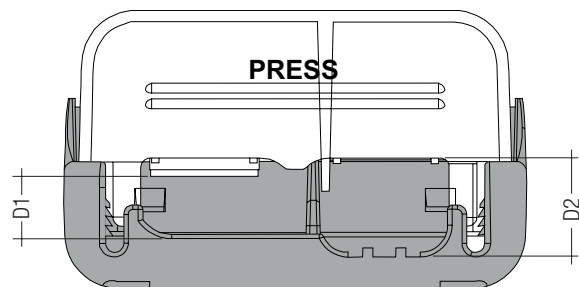

Depending on the used flaps of the terminal following cable jacket diameter difference between the side D2 and D1 terminals is recommended:

Side D1		Side D2		Difference D2 - D1
With flap	Without flap	With flap	Without flap	
x	-	-	x	4 mm
-	x	-	x	2 mm
x	-	x	-	2 mm
-	x	x	-	0 mm

### Wiring instructions

The secondary leads should be separated from the mains connections and wiring for good EMC performance.

The maximum lead length on secondary side is 2 m. For a good EMC performance keep the wiring as short as possible.