

NETYS RT

5000-7000-9000-11000 VA

Installation and operating manual 

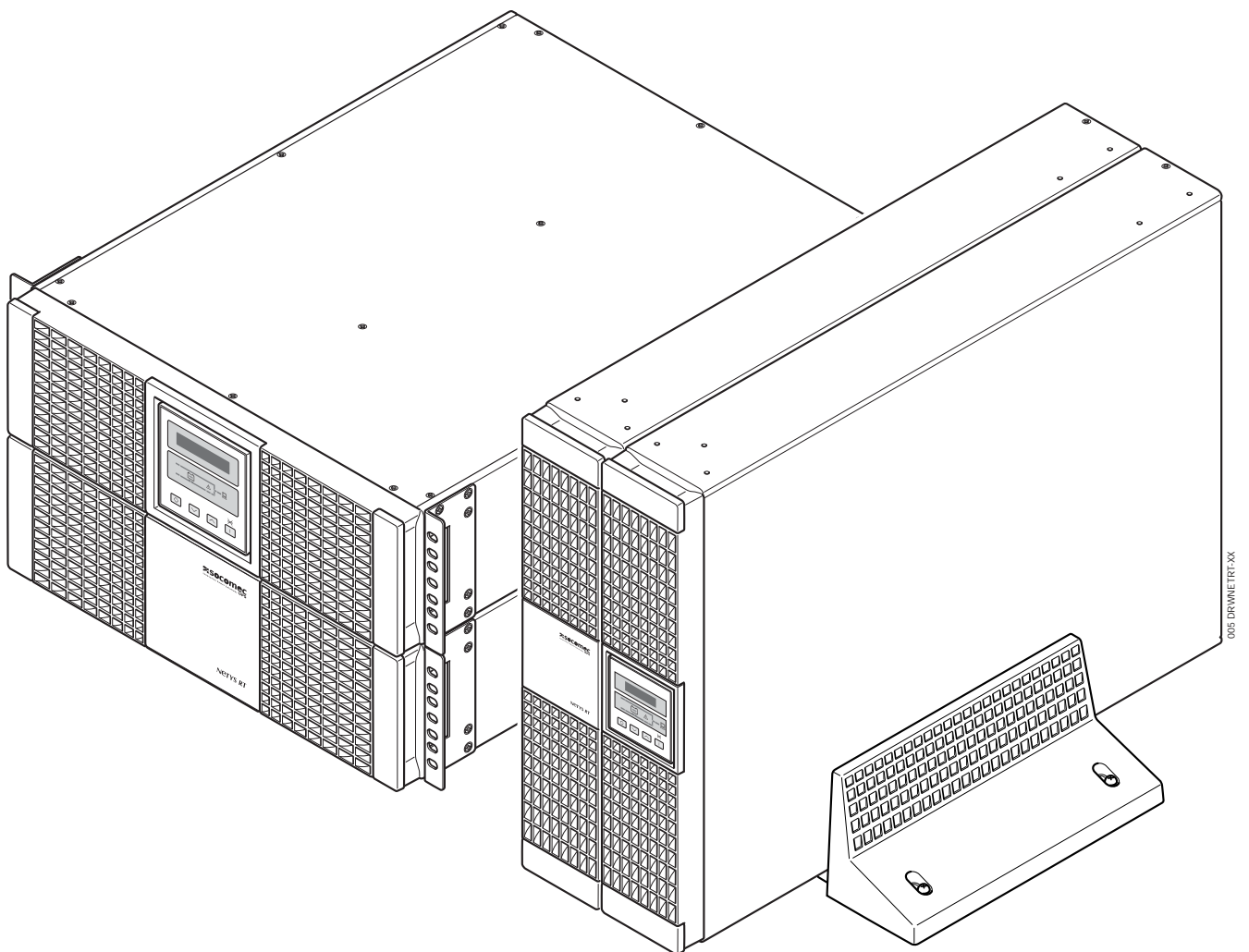

005 DRWNET RT-E-XX

WARRANTY CERTIFICATE AND CONDITIONS

This SOCOMEC UPS appliance is guaranteed against possible defects of manufacture and materials, for a period of 12 months from the date of purchase (local warranty conditions are applicable in addition to the general conditions). The present warranty certificate should NOT be mailed, but kept by the customer together with the proof of purchase document, for use in the event of a claim being made for repairs or replacement under warranty.

The warranty period runs from the date on which the new product was purchased by the end user at the showroom of an official resaler (the reference data is that indicated on the proof-of-purchase document).

The warranty is offered on carry-in terms: components and labour for repairs supplied free of charge, and in the case of a replacement, the product to be returned to SOCOMEC UPS or to authorized service centres, at the customer's own risk and expense.

To claim service under warranty, the user must abide by the following rules:

- The product is to be returned only in the original packing. Any damage occurring in transit to a product not in its original packing will not be covered by the warranty;
- The product must be accompanied by proof of purchase: a document (delivery note, invoice, counter receipt) indicating the date of the purchase, which must also indicate the essential identification data for the product (model, serial number). The sender must also attach the acceptance number issued to authorize the return of the product, together with a detailed description of the defect encountered. If any of these elements is missing, the warranty will be invalidated. The authorization number is issued by service centres over the telephone, after being informed of the malfunction in respect of which a claim is submitted;
- Should it be impossible to furnish proof of purchase, the serial number and date of manufacture will be used to calculate the probable expiry date of the warranty; this could result in a reduction of the original warranty period.

The warranty on the product does not cover damage occasioned by thoughtlessness (improper use: wrong input power, explosions, excessive humidity, temperature, poor ventilation, etc.), tampering or any unauthorized repair work.

During the warranty period, SOCOMEC UPS remains at liberty to decide whether the product should be repaired, or whether to replace defective parts with new parts, or with used parts that are equivalent to new parts in terms of functionality and performance.

In the case of batteries, warranty is valid only if the battery has been recharged periodically in accordance with the manufacturer's directions. Accordingly, it is advisable to check, following purchase, that the date of the next recharge indicated on the packing has not expired.

Optionals.

A 12-month carry-in warranty is offered on optionals.

Software products.

Software products are guaranteed for 90 days. The software is guaranteed to work substantially as indicated in the manual accompanying the product. Hardware media or accessories (e.g. diskettes, cables, etc.) used with appliances are guaranteed free of material or manufacturing defects under normal conditions of use for a period of 12 months from the date of purchase.

On no account will SOCOMEC UPS acknowledge liability for damages (including loss of income, interruption of business activity, loss of information or other economic losses, of whatever magnitude) deriving from the use of the product.

The present conditions are regulated by the laws of Italy. Disputes shall be submitted to the jurisdiction of the Vicenza Law Courts.

SOCOMECS UPS retains the full and exclusive ownership rights over this document. Only a personal right to utilize the document for the application indicated by SOCOMEC UPS is granted to the recipient of such document. All reproduction, modification, dissemination of this document whether in part or whole and by any manner are expressly prohibited except upon Socomec's express prior written consent.

This document is not a specification. SOCOMEC UPS reserves the right to make any changes to data without prior notice.

TABLE OF CONTENTS

1. SAFETY STANDARDS	4
1.1 Important	4
1.2 Description of the symbols used on the labels applied to the unit.	5
2. INSTALLATION	6
2.1 Environmental requirements for installation	6
2.2 Electrical requirements	6
2.3 Vertical installation.	7
2.4 Horizontal installation on rack	9
3. REAR VIEW	13
4. CONNECTIONS	14
4.1 Connection terminal strips	14
4.2 Connection of UPS	15
5. CONNECTION OF BATTERY EXTENSION	16
5.1 Safety warnings	16
5.2 Connection of battery extension	16
6. CONNECTION OF BY-PASS AND SINGLE UPS	18
6.1 Installation of BY-PASS and single UPS	18
6.2 Connection of BY-PASS to single UPS	19
7. CONNECTION OF BY-PASS AND UPS IN PARALLEL	23
7.1 Vertical installation of BY-PASS and UPS in parallel	23
7.2 Rack installation of BY-PASS and UPS in parallel	24
7.3 Connection of BY-PASS and UPS in parallel.	25
7.4 Connection of BY-PASS to UPS in parallel	27
8. MIMIC PANEL	28
9. OPERATING MODES	29
9.1 Basic settings	29
9.2 Operation in BY-PASS mode for maintenance purposes - single UPS	30
9.3 Operation in BY-PASS mode - UPS in parallel for maintenance purposes	32
10. COMMUNICATION	33
10.1 Communication solutions	33
10.2 RS232 interface	33
10.3 Integrated WEB/SNMP card	33
10.4 Use of warning relay interface	33
11. MAINTENANCE	36
11.1 Minor troubleshooting	36
12. TECHNICAL SPECIFICATIONS	37

1. SAFETY STANDARDS

1.1 Important

This manual should be kept carefully in a safe place near the UPS, so that it can be consulted by the operator at any time for any information that may be needed regarding correct use of the unit. Read the manual carefully before connecting the unit to the a.c. mains supply and to the downstream appliances. Before the UPS NETYS RT is put into commission, the user must be perfectly familiar with its operation, with the position of all the controls and with the technical and functional characteristics of the unit, so as to ensure there will be no risk to any persons or to the appliance itself.

- **The electrical installation must be entrusted EXCLUSIVELY to a skilled engineer**, following the instructions provided exactly.
- **Before being started up, the unit must be equipotentially bonded, in accordance with current safety regulations.** The earth wire of the UPS must then be connected to an efficient earth system.
- **If the earth connection is not made, the appliances connected to the UPS will not be equipotentially bonded.** In this situation, the manufacturer declines all liability for any damage or accidents that could derive from failure to observe the requirements.
- **Should a power outage occur (UPS in stand-alone mode), do not disconnect the power cord from the mains, as this will break the earth connection to bonded appliances.**
- **All subsequent maintenance operations must be entrusted only to authorized service engineers.** The UPS generates high internal voltages that could be hazardous for a maintenance operative not in possession of the appropriate skills and training for this type of work.
- **If a hazard situation should arise at any moment when the UPS is in use**, isolate the unit from the power supply (by operating a switch at the upstream PDU if possible) and switch the appliance off completely by running the shutdown procedure.
- **The UPS houses a source of electrical energy, namely its batteries. The output of the UPS may be under power even when the appliance is not connected to the a.c. mains supply.**
- **Never force, break or attempt to open the batteries. These batteries are sealed, maintenance-free components containing substances that are harmful to health and a source of environmental pollution. If liquid can be seen leaking from the battery, or a white powdery residue is noticeable, do not switch the UPS on.**
- **Avoid exposing the UPS to contact with water or any liquids generally. Do not allow foreign objects to come into contact with the materials.**
- **If the appliance is to be scrapped**, it must be entrusted exclusively to a specialist waste disposal company. These companies will split up and dispose of the various components in accordance with statutory regulations in the country of purchase.
- Use the UPS in accordance with the technical specifications indicated in this manual (chapter 11).
- Avoid connecting the output neutral to earth. The UPS does not alter the function of mains neutral in any way; if neutral needs to be modified downstream of the UPS, an isolation transformer must be used.
- To meet the operating requirements for the Emergency Switch Device (ESD), a specific RJ11 input with remote ESD/EPO function is available.
- In the event that the equipment has no automatic backfeed protection contactor device, make certain that:
 - the user/installer attaches warning labels to all mains isolating switches located remotely from the area where the UPS is sited, in order to inform service personnel that the circuit is connected to a UPS.
 - an external isolating device is installed, as indicated in figure 1-1.
- The product you have selected, given the specified conditions of use, capacity and performance limits, is designed exclusively for commercial and industrial service. The use of the product in "critical applications" could require compliance with statutory regulations and standards, or with specific local bylaws, or adaptation to SOCOMEC UPS recommendations. For this type of use, in any event, it is advisable to contact SOCOMEC UPS beforehand for confirmation regarding the capacity of products to meet required levels of safety, performance and reliability. The expression "critical applications" covers, in particular, life support systems, medical applications, commercial transport, nuclear facilities or any other systems where failure of the product might on occasion cause serious damage to persons or property.



WARNING!

This is a product for commercial and industrial application in the second environment – installation restrictions or additional measures may be needed to prevent disturbances.

1.2 Description of the symbols used on the labels applied to the unit

All the precautions and the warnings on the labels and plates on the inside and outside of the equipment should be respected.



DANGER! HIGH VOLTAGE (BLACK/YELLOW)



GROUND TERMINAL



READ THE USER MANUAL BEFORE USING THE UNIT

2. INSTALLATION

2.1 Environmental requirements for installation

Consult the following check list when installing the UPS:

- NETYS RT units are designed for use in enclosed environments.
- Position the UPS on a flat and stable surface in a properly ventilated room, well away from heat sources and avoiding direct exposure to sunlight.
- Ambient temperature should be maintained between 0 °C and 40 °C, and relative humidity below 90% (without condensation); the optimum temperature in terms of maximizing battery life is 15-20 °C.
- Check that the UPS will not be installed in a dust-laden environment.
- Be certain that a clearance of at least 20 cm is left on all sides of the unit to ensure adequate ventilation and provide access to the rear panel.
- Take care not to stand the UPS or any other heavy object on cables.
- Check that the operating voltage and frequency settings are correct for the mains power supply at the installation site. Details for the UPS will be found on the data plate affixed to the rear panel.
- When making the RS232 serial connection, use only the cables and accessories supplied or specified by the manufacturer.
- When the UPS is first used, it is advisable to leave the battery on charge for a minimum of 8 hours.



PRECAUTIONS IN THE EVENT OF DAMAGE DO NOT OVERTURN THE BATTERIES.

Packing materials that have been broken, punctured or torn in such a way as to reveal the contents must be kept separate in a secure area, and inspected by skilled staff. Any packing considered unsuitable for shipment of the contents must be set aside immediately and kept secure, and the sender or recipient contacted.

2.2 Electrical requirements

The installation and the system must comply with pertinent national statutory regulations.

The fixed power distribution unit must include protection and isolation for the utility supply and the back-up supply. In the event that a residual current device is installed on the UPS input line (optional), this must be located upstream of the power distribution unit.

The following table indicates the sizing of input protection devices that will ensure correct installation.



WARNING!

Use type B four-pole selective (S) RCDs Any leakage currents at the loads will be added to that of the UPS, so that current peaks can occur during transients (loss and restoration of mains supply), although these will be of very short duration. Where loads generate high leakage current, make certain the rating of the RCD is suitably matched. In any event, always conduct a preliminary test for current leakage to earth

Electrical requirements			
UPS	Thermal-magnetic switch on input	Recommended selective RCD on input	Minimum cable section
5 kVA	40 C	0,1 A type B	6 mm ²
7 kVA	40 C	0,1 A type B	8 mm ²
9 kVA	63 D	0,1 A type B	10 mm ²
11 kVA	63 D	0,1 A type B	10 mm ²

2.3 Vertical installation

2.3.1 UPS Installation

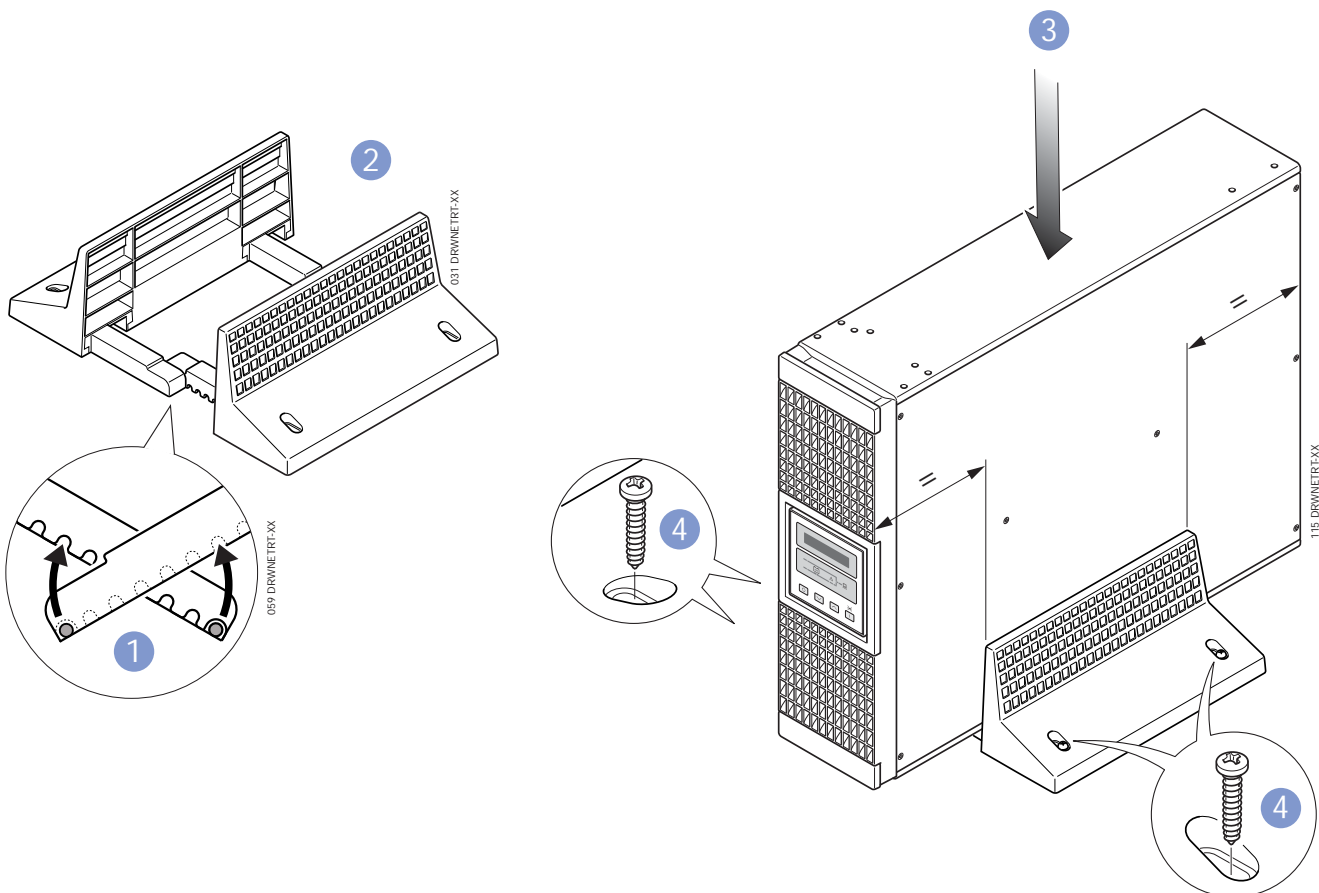
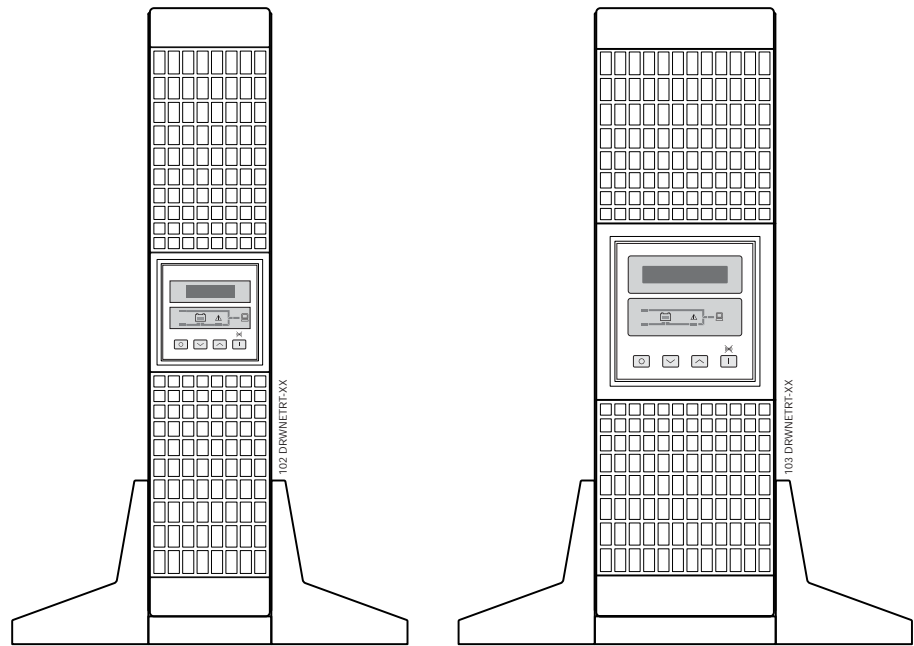

2.3.2 UPS installation with multiple battery extensions

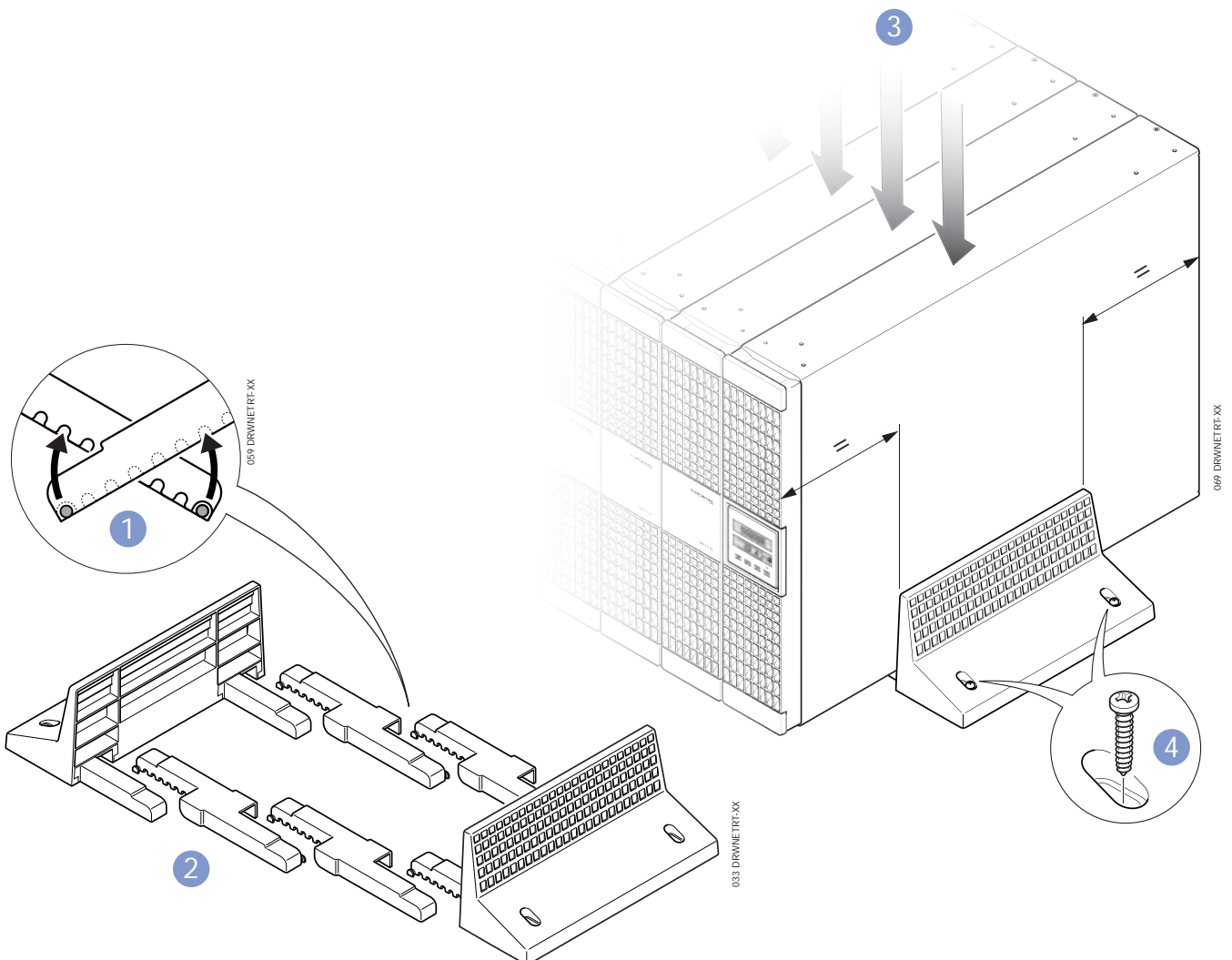
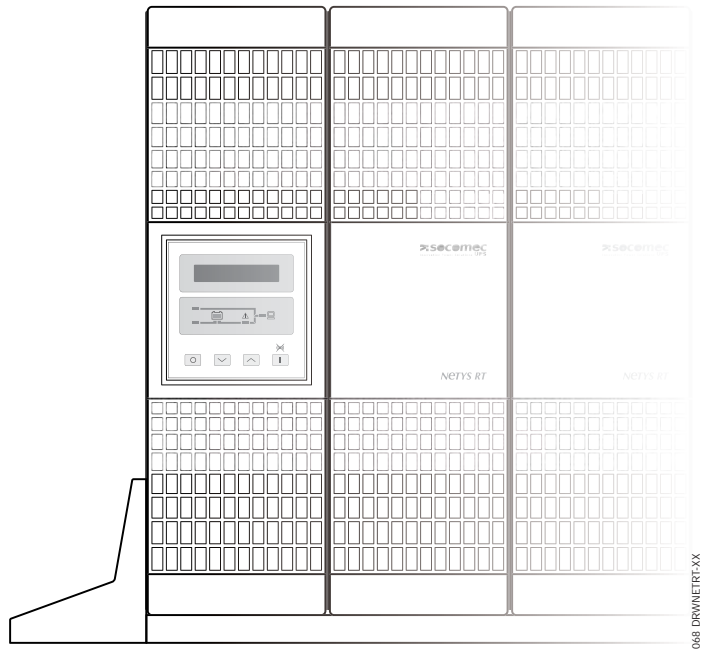
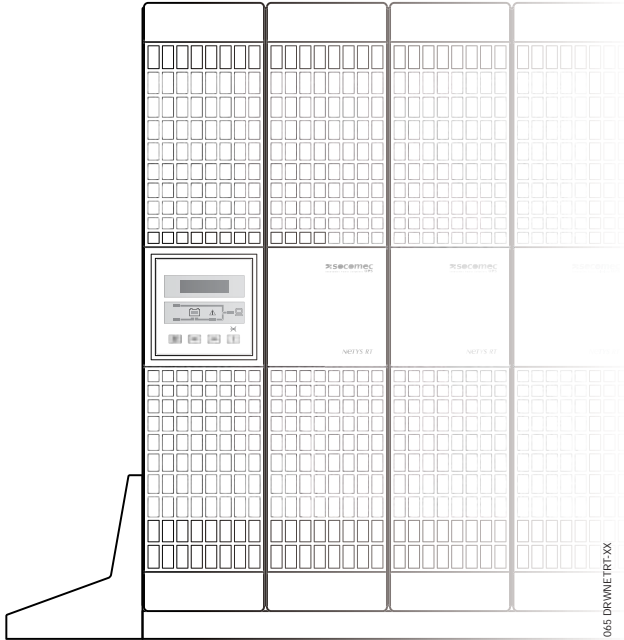

2.4 Horizontal installation on rack

2.4.1 Rotation of mimic pannel

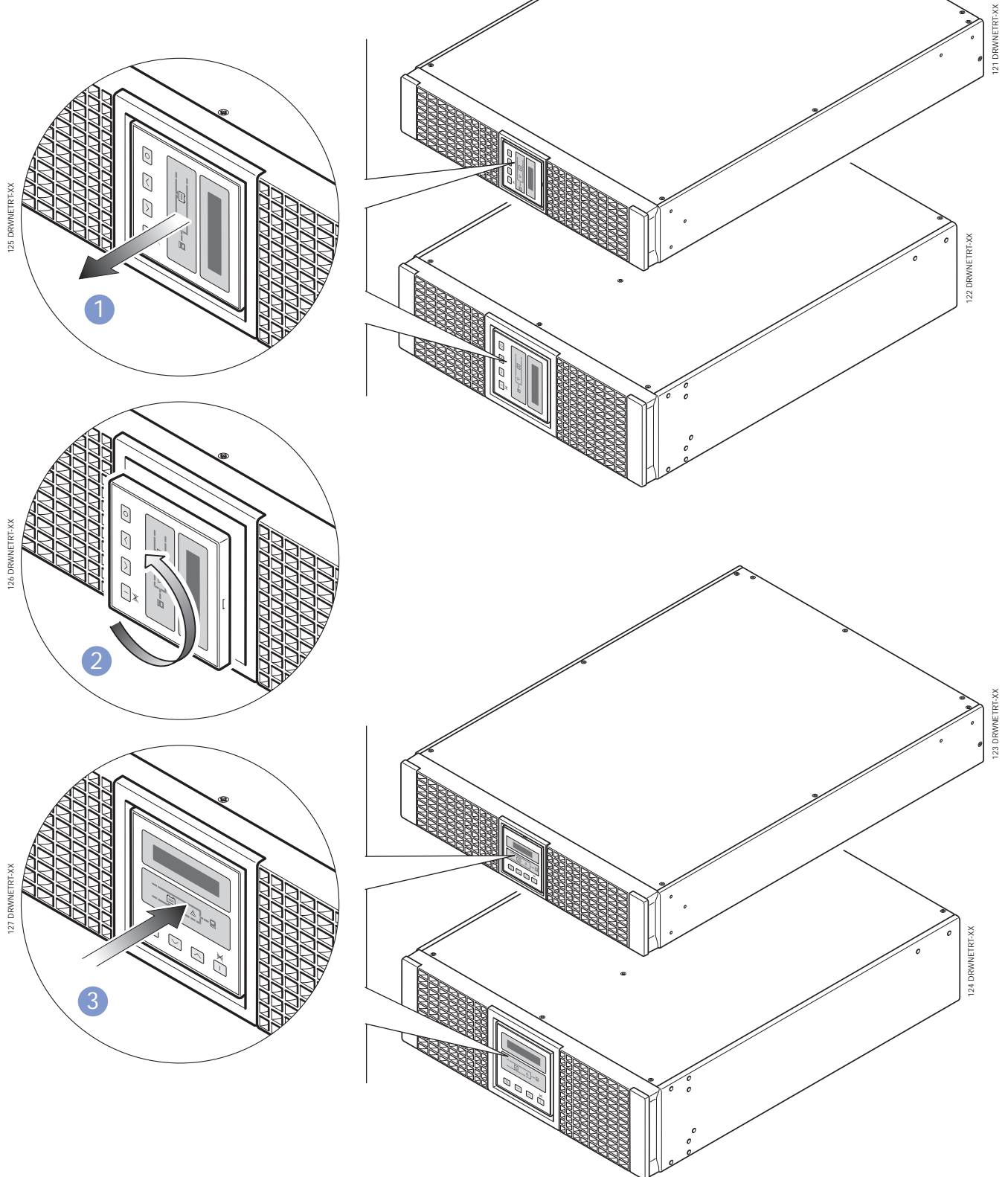

2.4.2 Fitting rack brackets

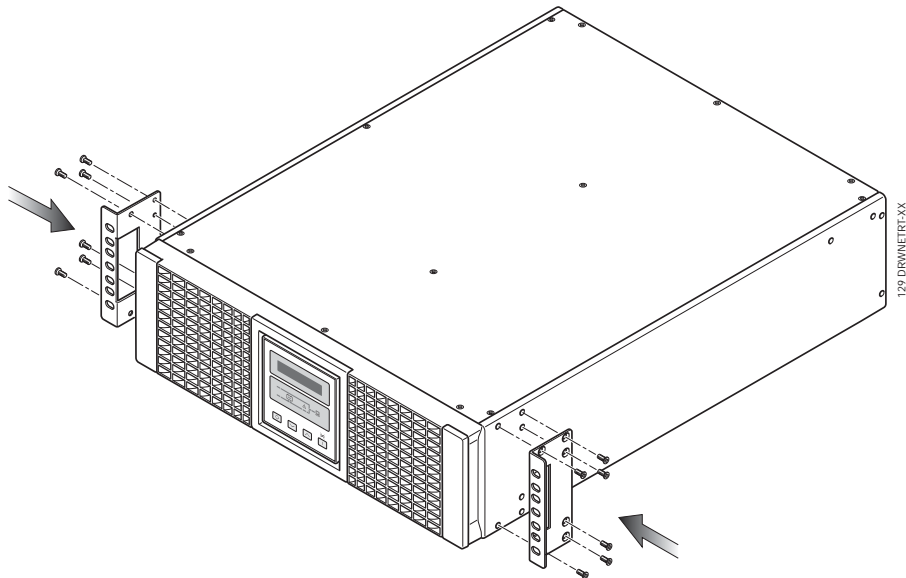
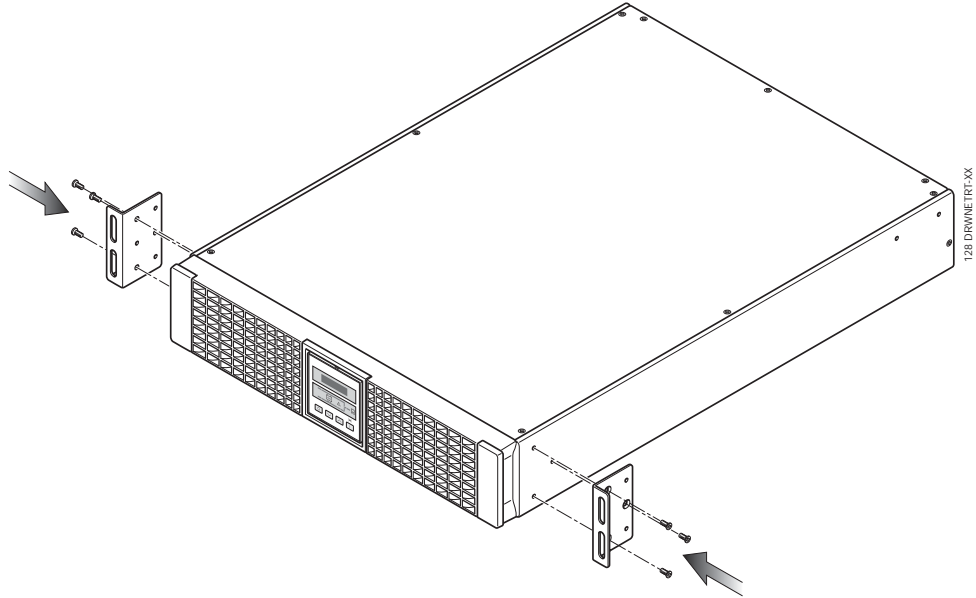

2.4.3 Rotation of battery extension panel

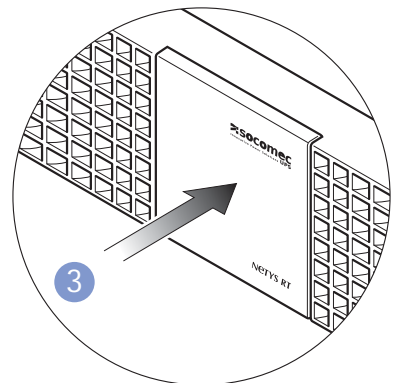
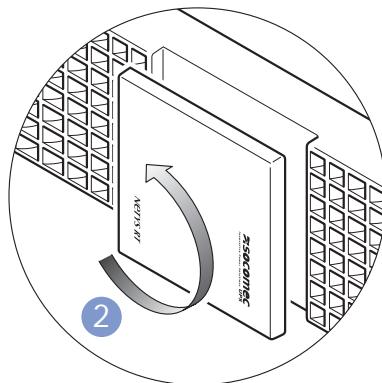
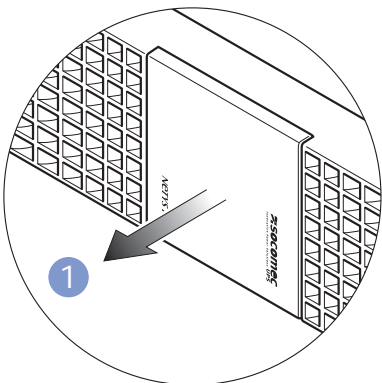
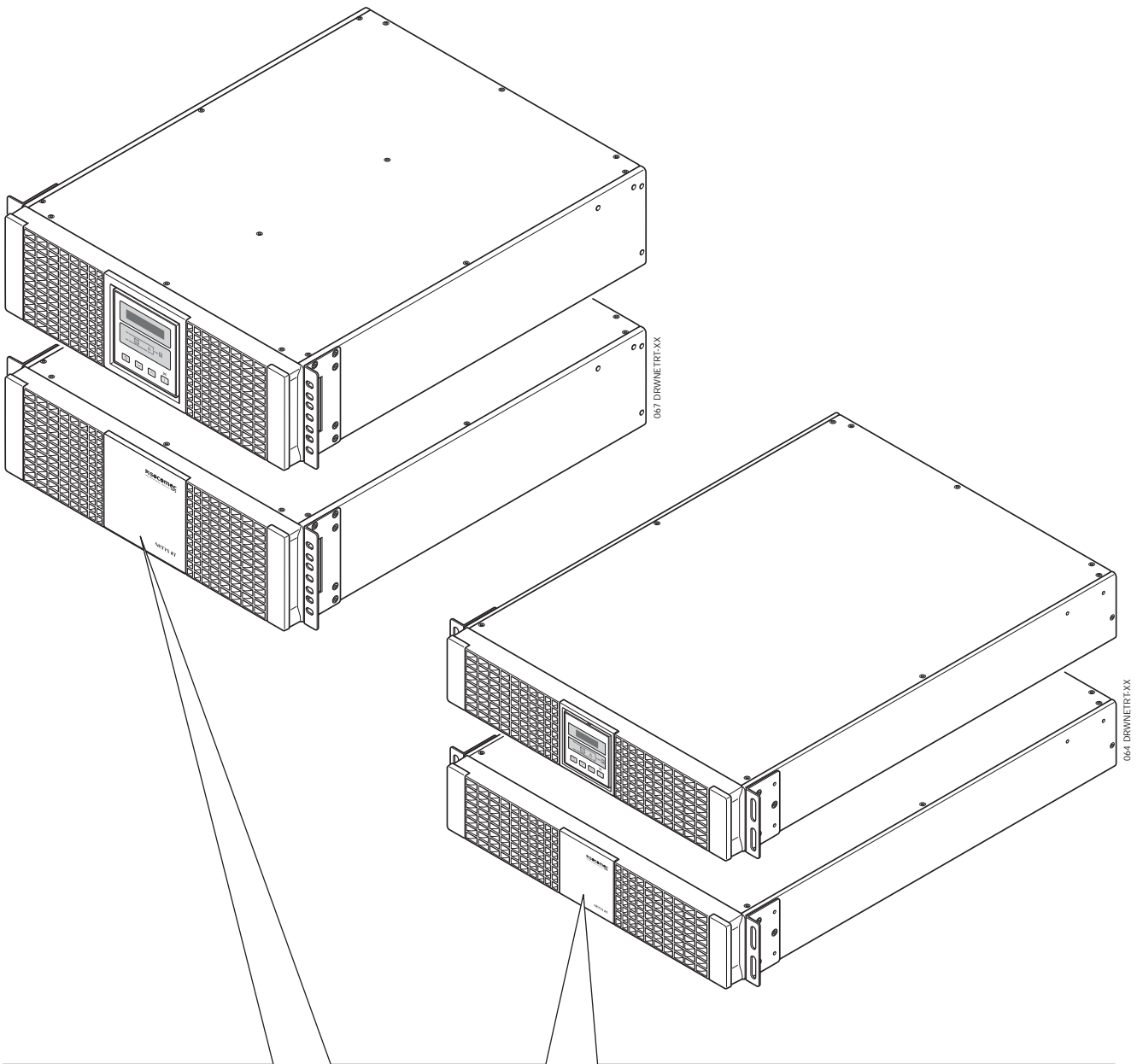

2.4.4 Fixing to rack

1. Adapt the length of the tracks to fit the rack.
2. Secure the wing nuts.
3. Fix the track to the rack.
4. Slot in the UPS and tighten the screws.

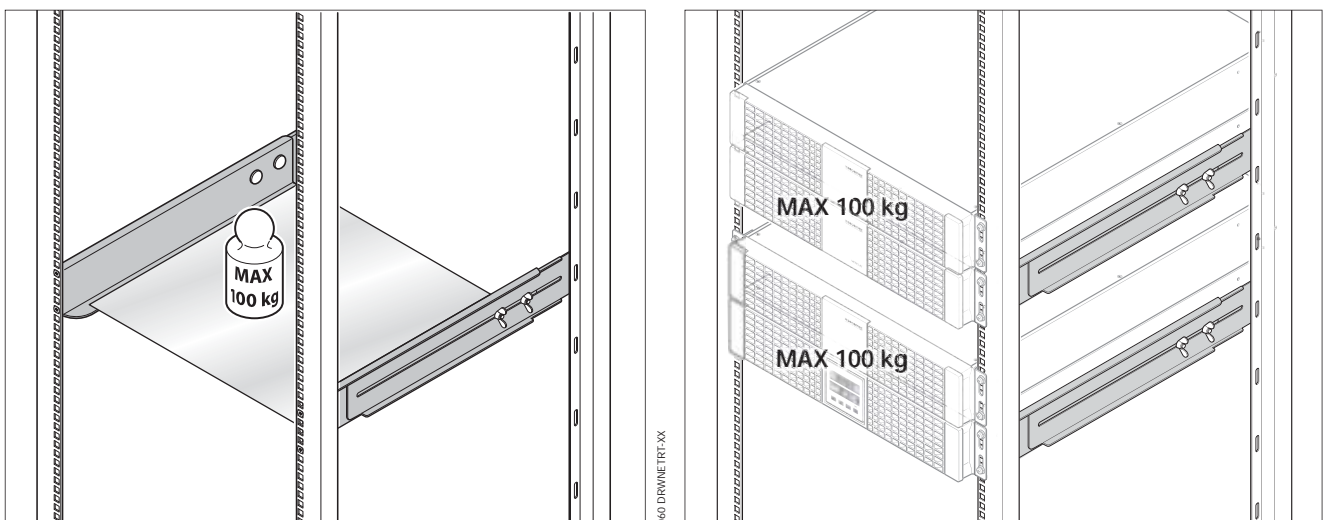
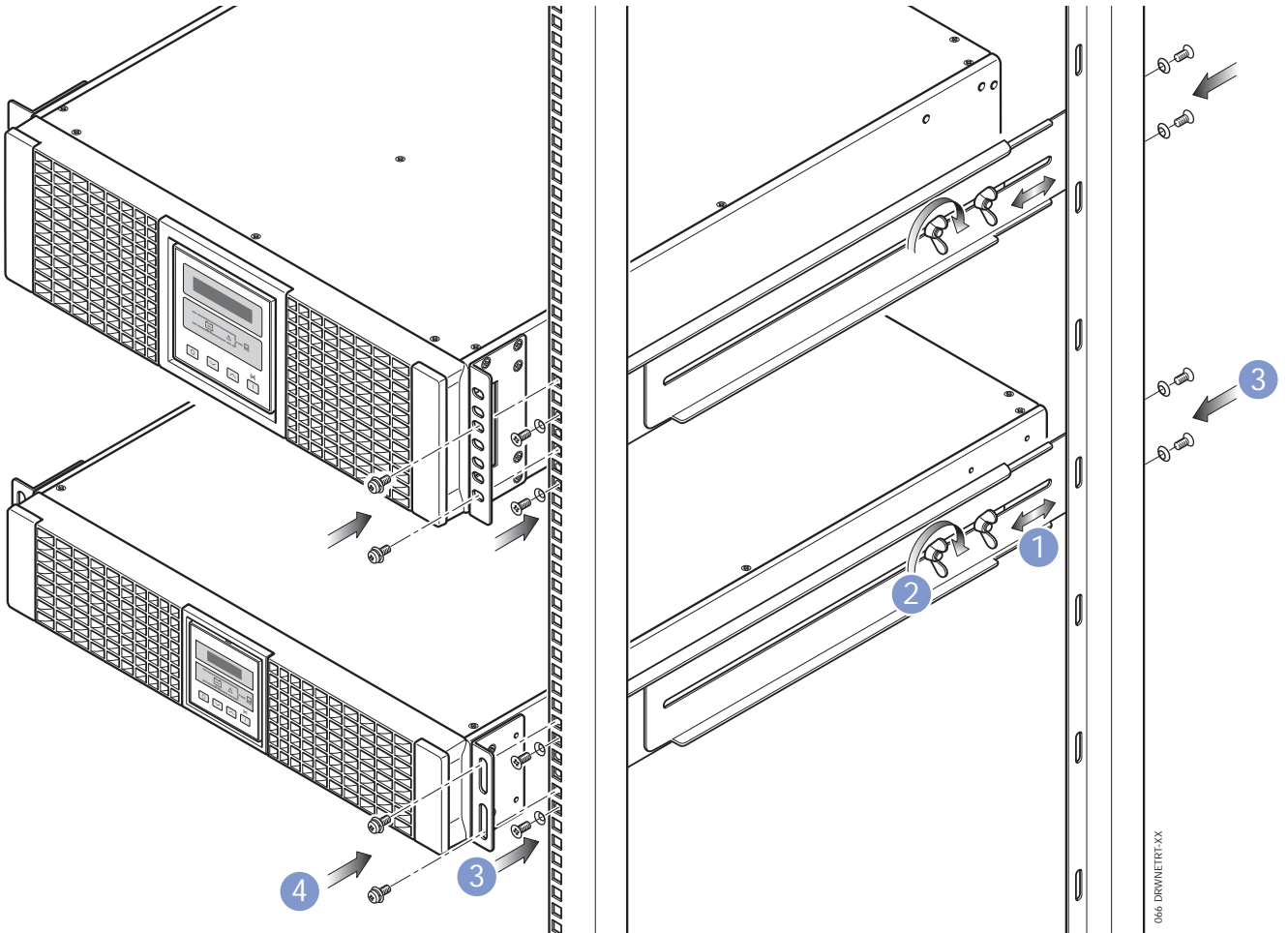

3. REAR VIEW

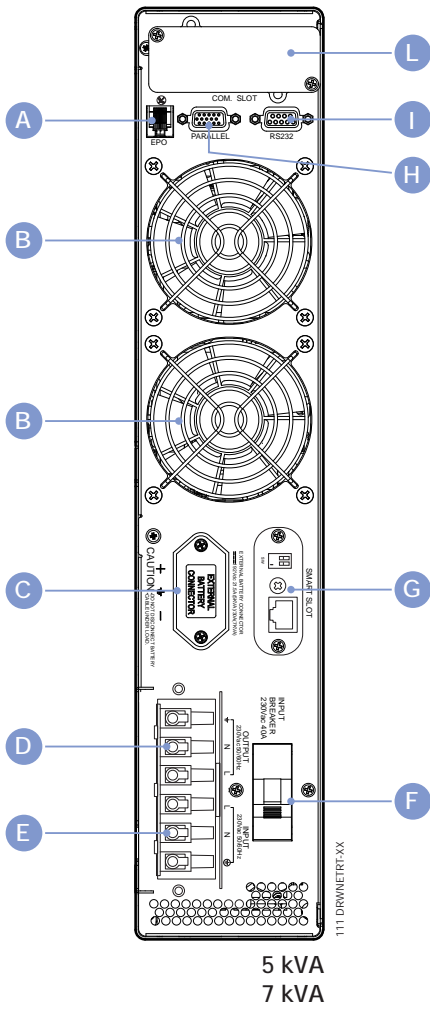

5 kVA
7 kVA

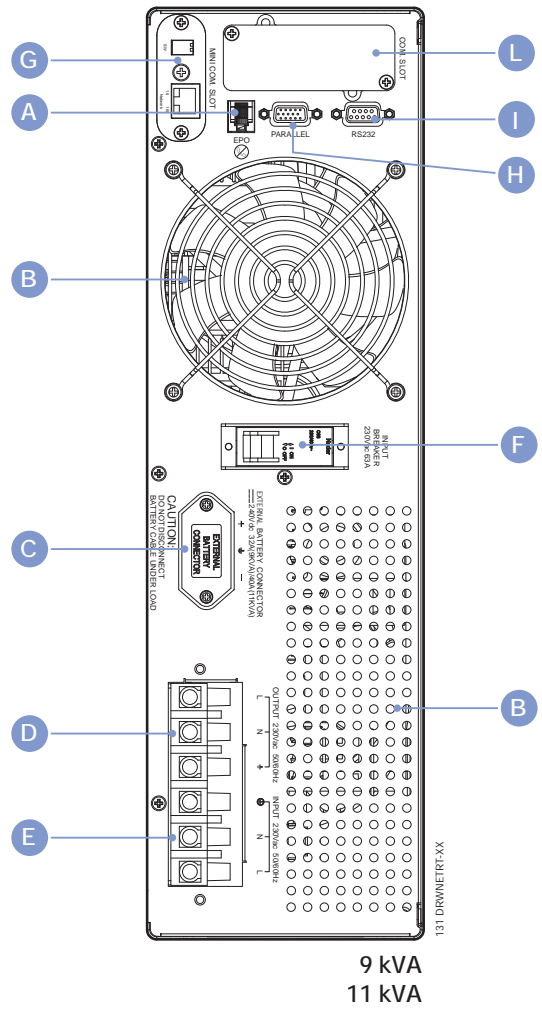

9 kVA
11 kVA

Legend

- A EPO (Emergency Power Off)
- B Fan
- C Battery extension socket
- D Output terminals
- E Input terminals
- F Input switch
- G RJ45 LAN ethernet connector
- H Parallel D connector
- I RS232 serial connector (JBUS protocol)
- L Slot for optional communication cards

If requested, the UPS can also be switched off utilizing a remote external EPO contact. The command is acknowledged when the contact is made and held for 3 seconds (default), as in figure 3-1.



The external contact **MUST** be dedicated and voltage-free, so as not to cause permanent damage to the UPS.

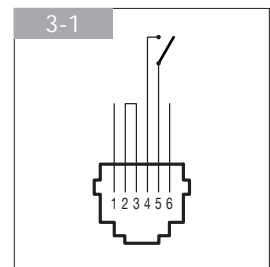

070 DRWNETRT-XX

4. CONNECTIONS

Connection to the mains power supply and to the load(s) must be made using cables of suitable cross section, in accordance with current standards.

If not already provided, install a PDU panel allowing isolation of the mains supply upstream of the UPS. The panel must be equipped with an automatic switch rated high enough to handle the current draw on full load, and with a residual current device.

4.1 Connection terminal strips

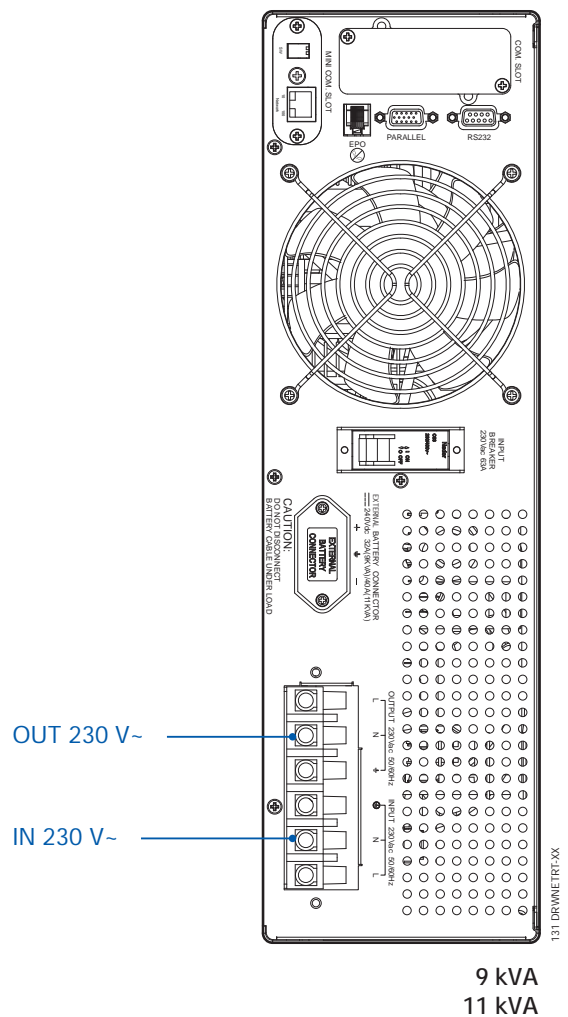
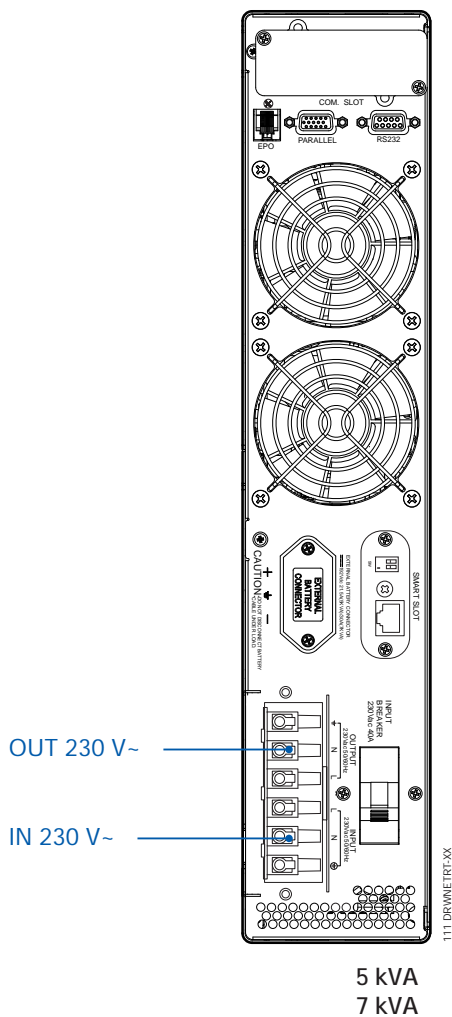

4.2 Connection of UPS

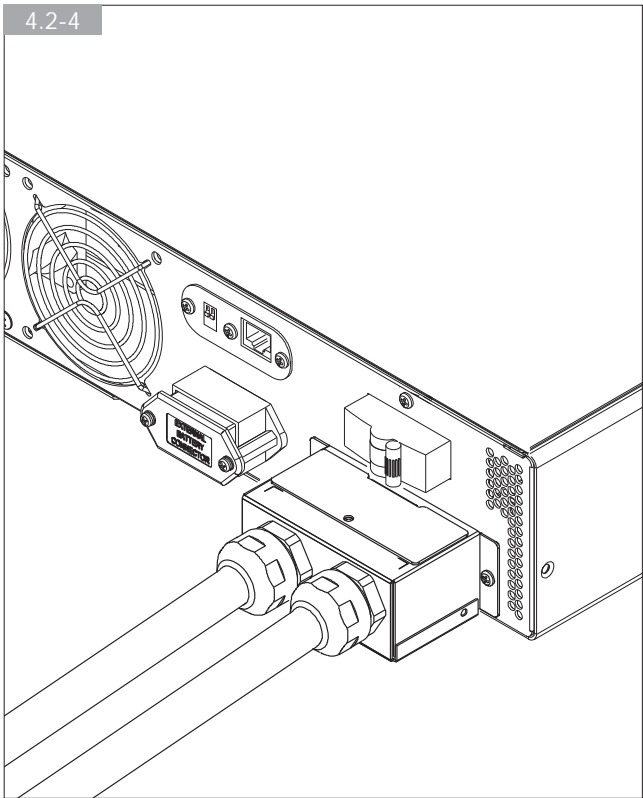
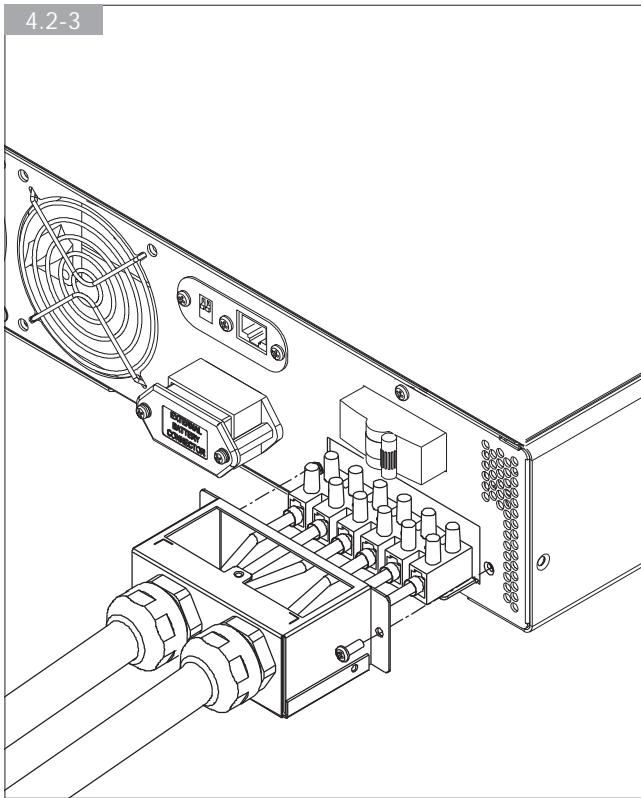
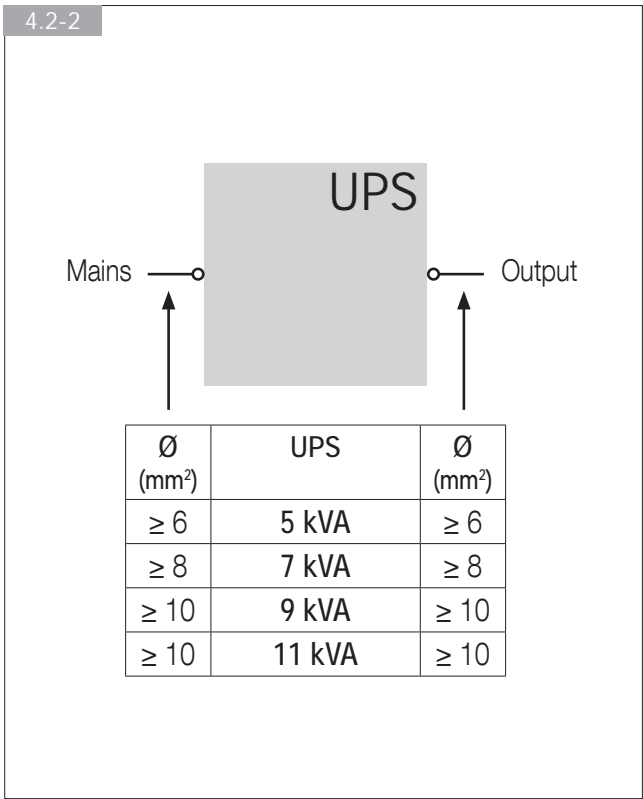
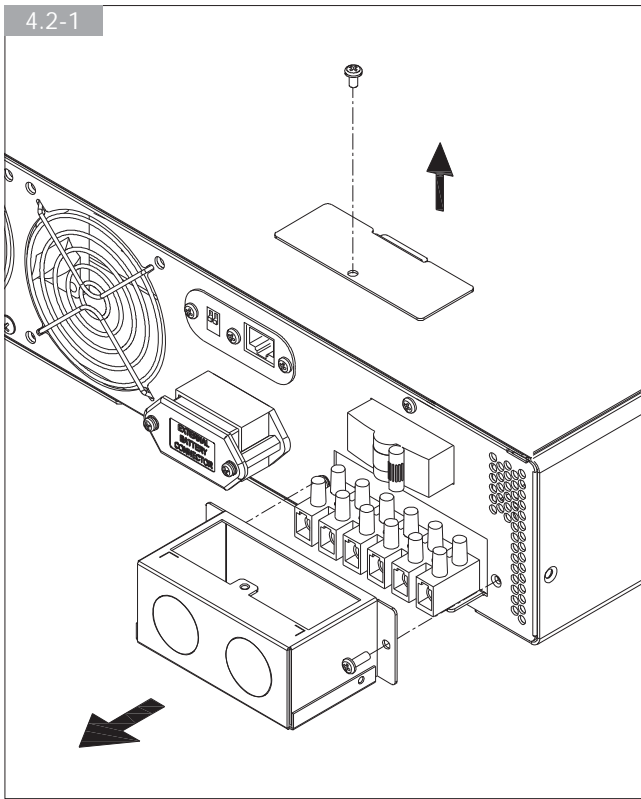

5. CONNECTION OF BATTERY EXTENSION

5.1 Safety warnings

- Before connecting the battery extension, check that it is fully compatible with the model of UPS in use.
- The use of battery extensions not supplied by the manufacturer is inadvisable.



WARNING!

There is a risk of explosion if battery modules are replaced with others of incorrect type.

- Depleted batteries are considered as toxic waste. When battery replacement becomes necessary, release all depleted batteries only to certified and licensed waste disposal companies. In accordance with local bylaws, it is absolutely forbidden to dispose of batteries together with other industrial waste or household refuse.



WARNING!

It is extremely dangerous to touch any part of the battery storage unit.

5.2 Connection of battery extension



WARNING!

Before commencing any operation, make certain that:

- the voltages of the UPS battery and of the battery extension are the same,
 - 5 kVA: 192 VDC (NRT-B7000)
 - 7 kVA: 192 VDC (NRT-B7000)
 - 9 kVA: 240 VDC (NRT-B11000)
 - 11 kVA: 240 VDC (NRT-B11000)
- the UPS has been shut down completely and all isolation switches are OFF;
- switches upstream of the UPS are OFF.



When connecting the UPS to the battery extension, use only the cable provided with the equipment.



Any wiring error that results in the polarity of the battery being inverted can cause permanent damage to the equipment.

- Set the switch on the back of the battery extension module to the OFF position.
- Connect the battery extension module to the UPS.
- To display the correct autonomy value the number of connected EBM has to be set via mimic panel.
- Set the correct charging current value according to the number of connected EBM via mimic panel.
- Set the switch on the back of the battery extension module to the ON position.

5. CONNECTION OF BATTERY EXTENSION

ON-OFF switch

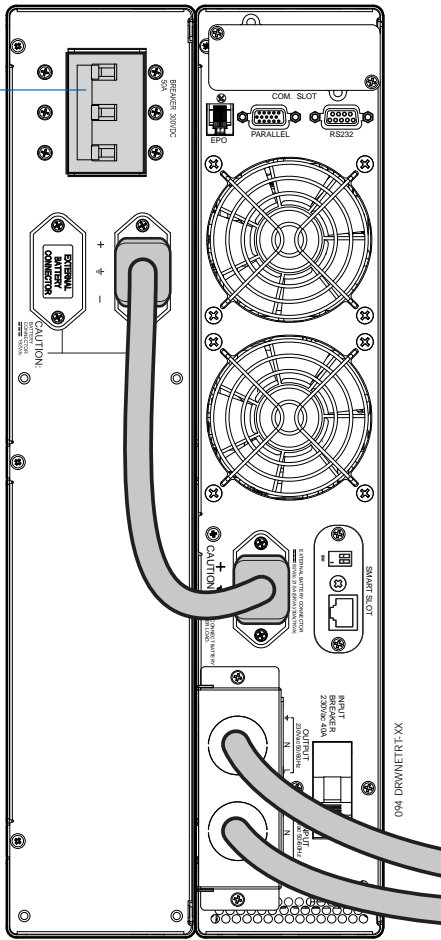

5 kVA
7 kVA

ON-OFF switch

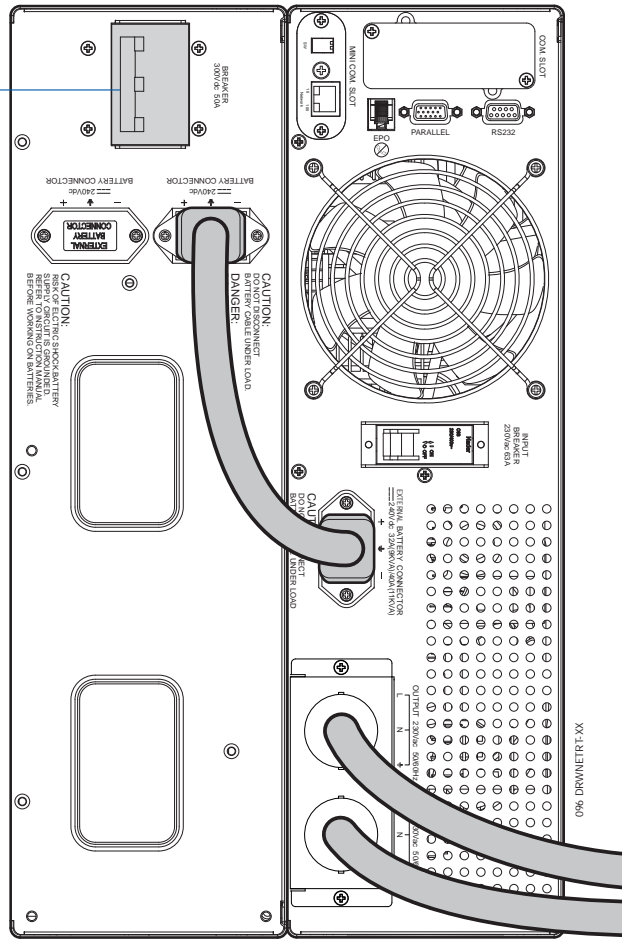

9 kVA
11 kVA

Connection of multiple batteries

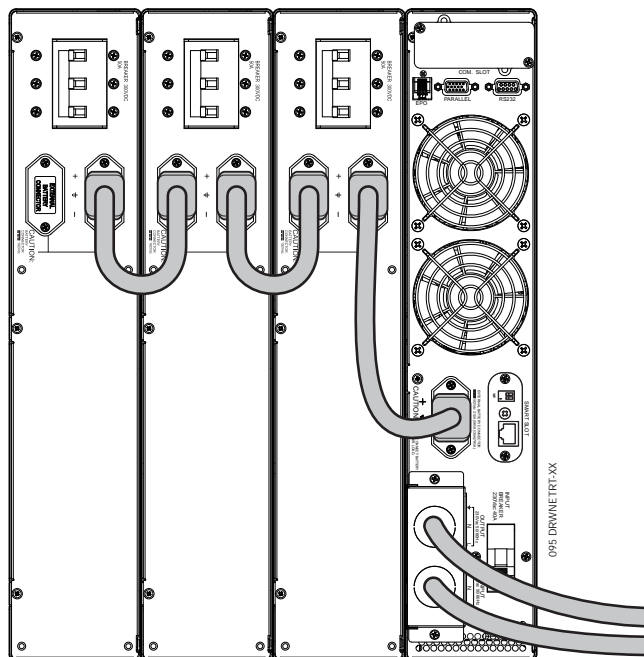

6. CONNECTION OF BY-PASS AND SINGLE UPS

6.1 Installation of BY-PASS and single UPS

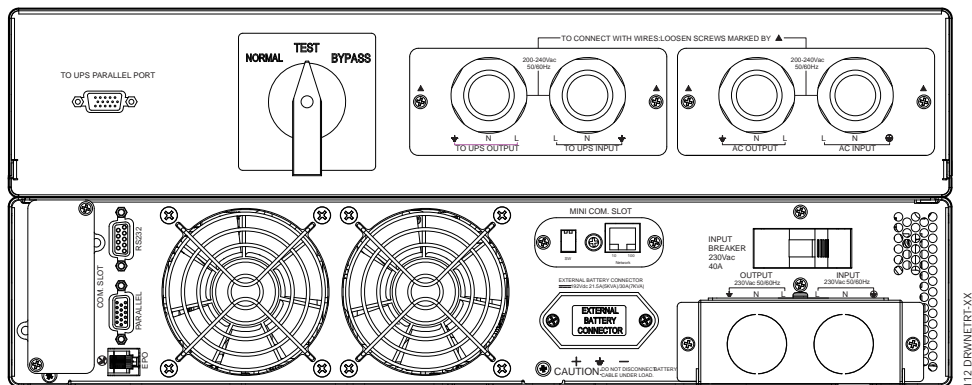

6.1.1 Fixing the BY-PASS to the UPS

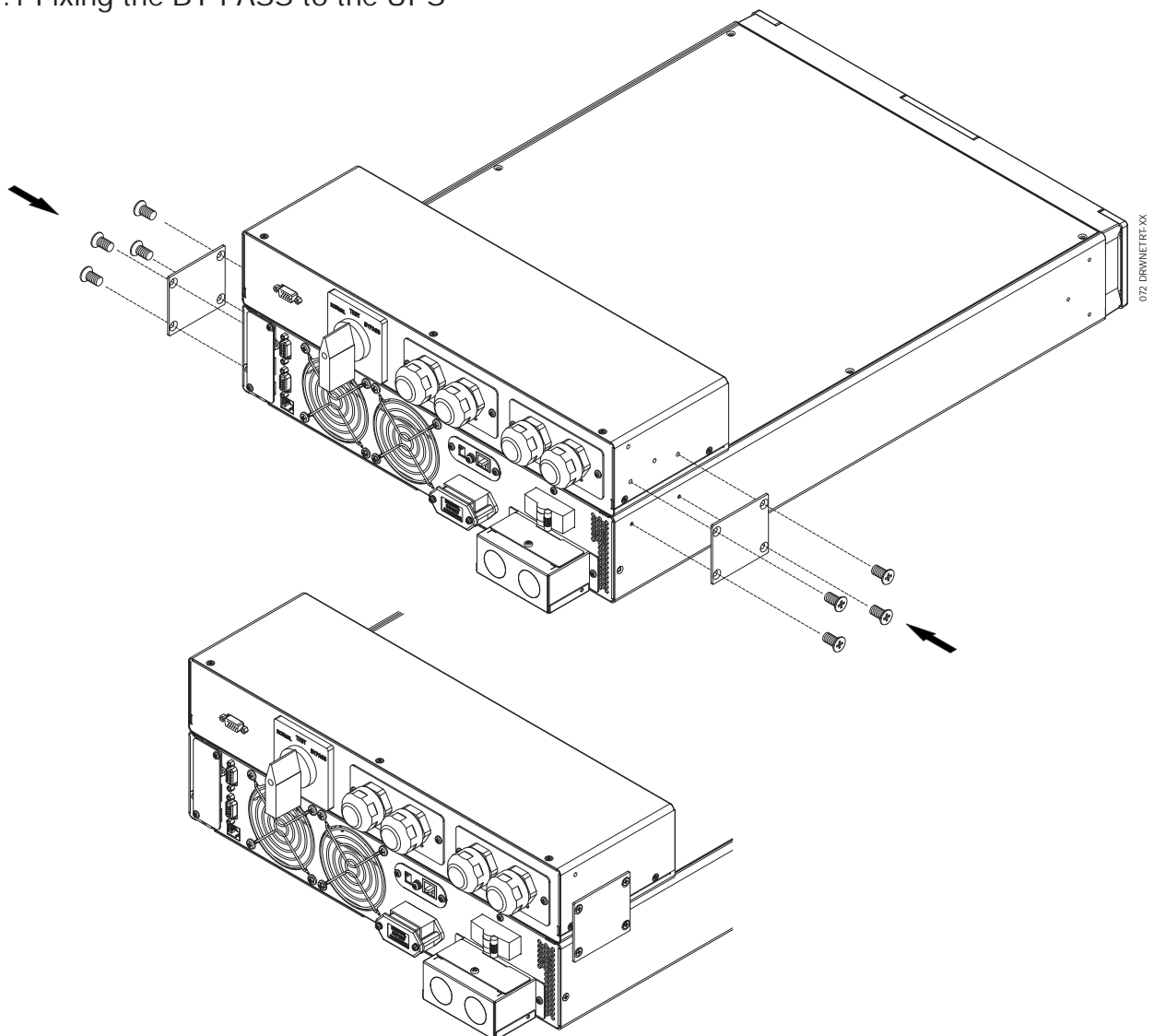

6.2 Connection of BY-PASS to single UPS

6.2.1 Fixing the BY-PASS to the UPS

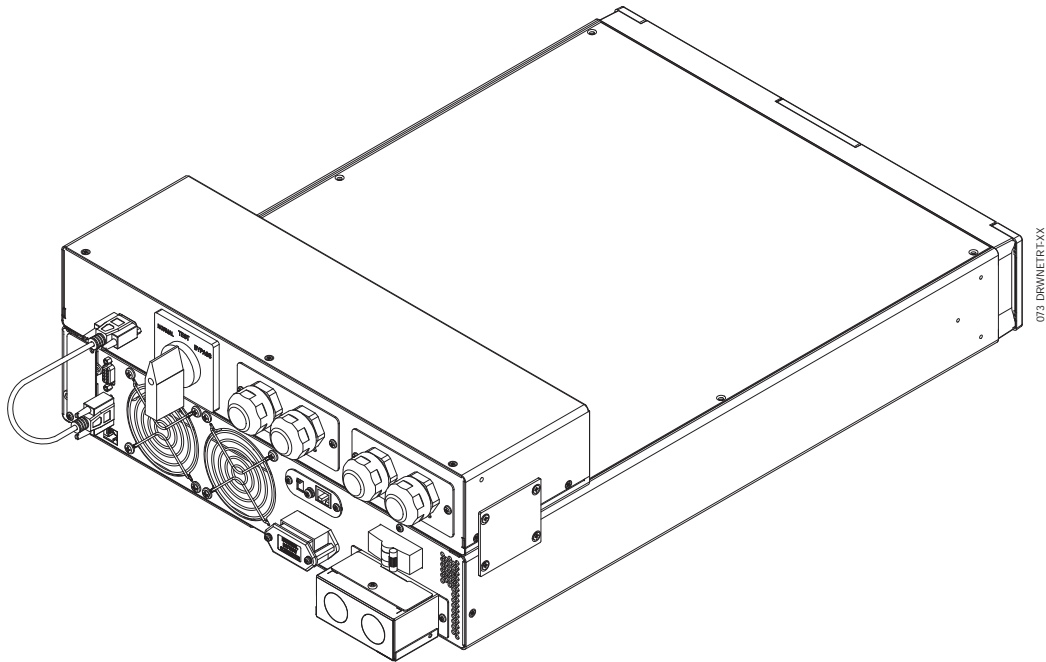

6.2.2 Signal connections between BY-PASS and UPS

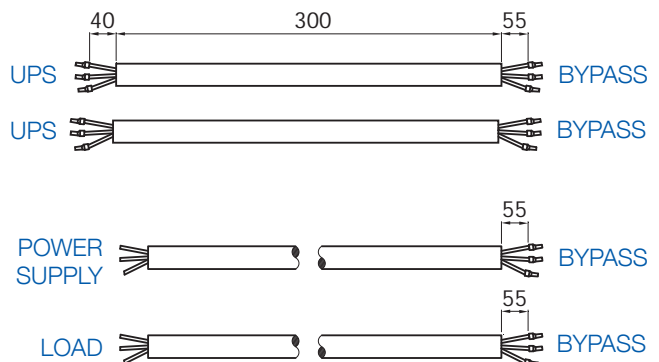
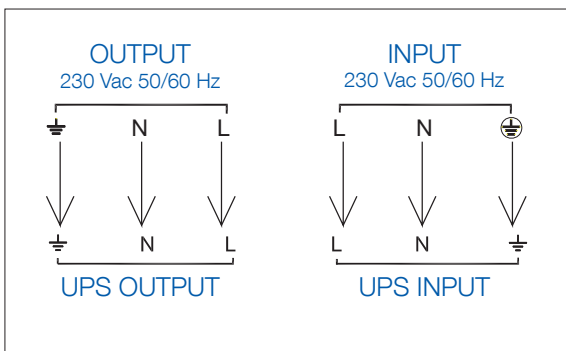

6. CONNECTION OF BY-PASS AND SINGLE UPS

6.2.3 Connection of cables to the UPS terminal strips

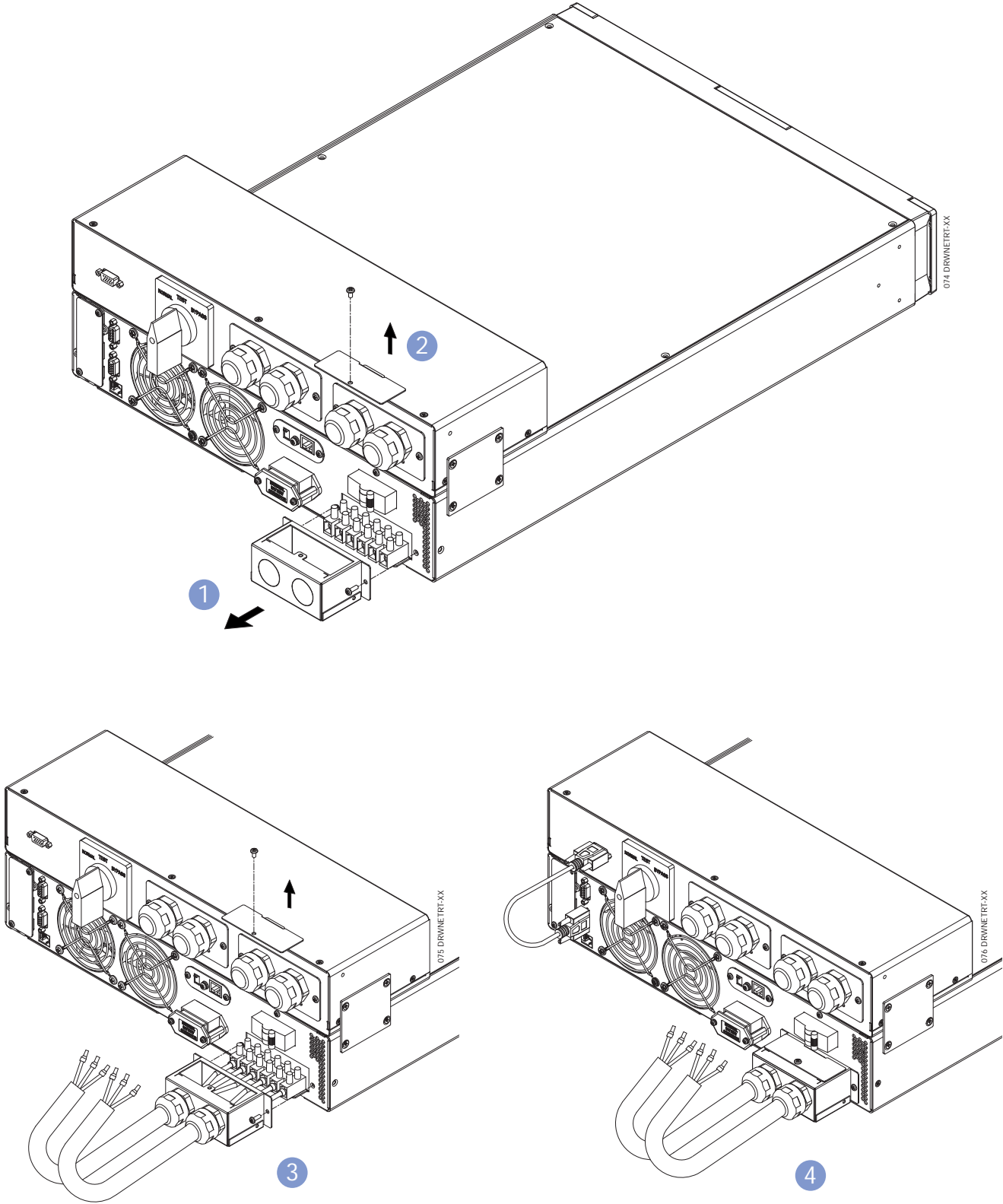

6.2.4 Connection of cables to the BY-PASS terminal strips

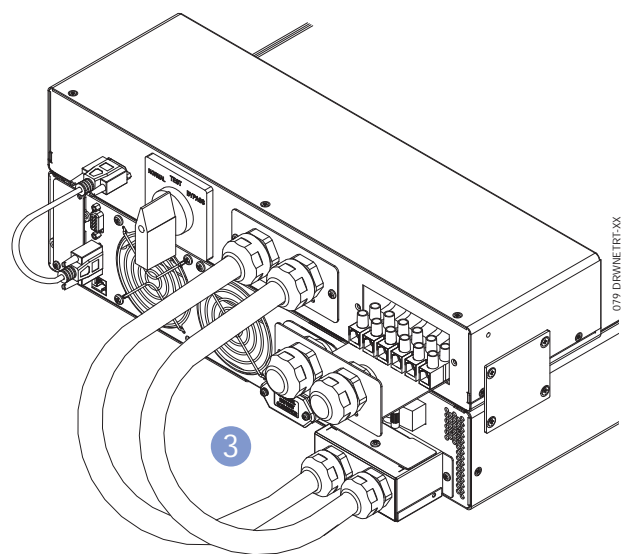
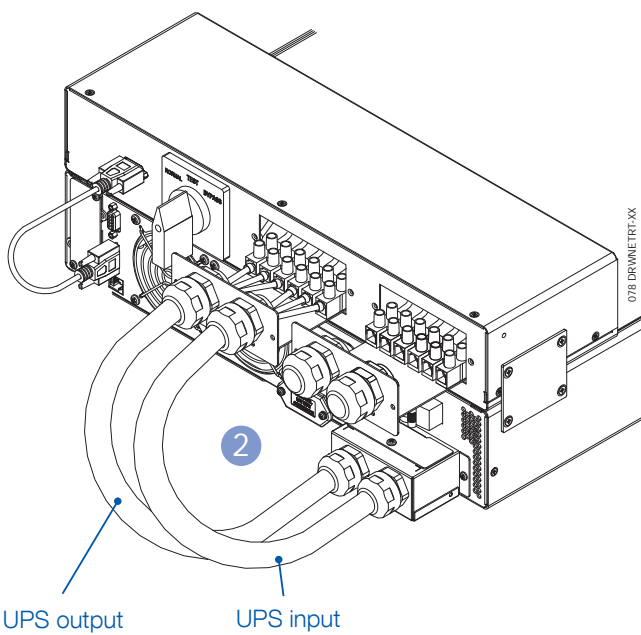
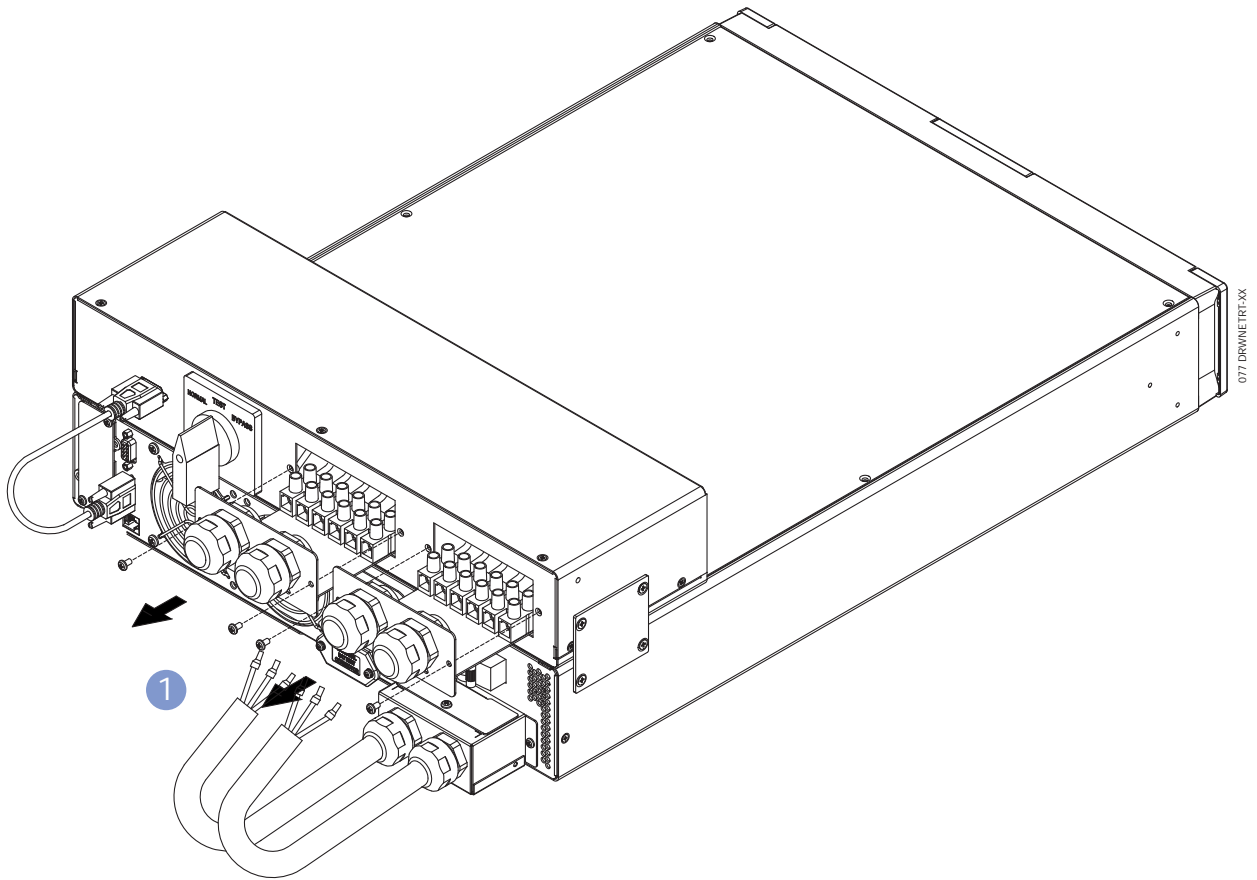

6. CONNECTION OF BY-PASS AND SINGLE UPS

6.2.5 Connection of cables to the BY-PASS input and output terminal strips

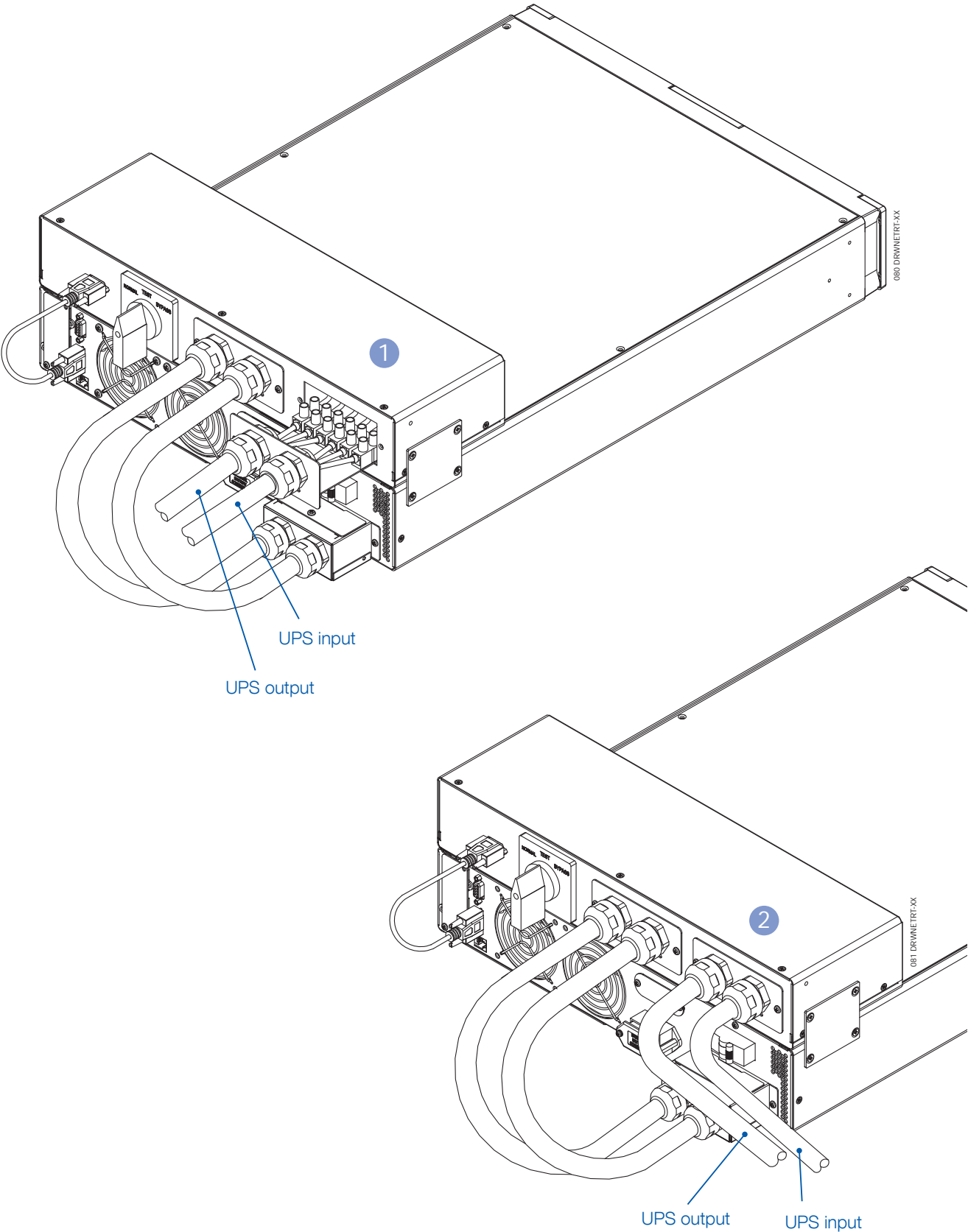

7. CONNECTION OF BY-PASS AND UPS IN PARALLEL

7.1 Vertical installation of BY-PASS and UPS in parallel

7.1.1 Assembly of BY-PASS and UPS for vertical installation

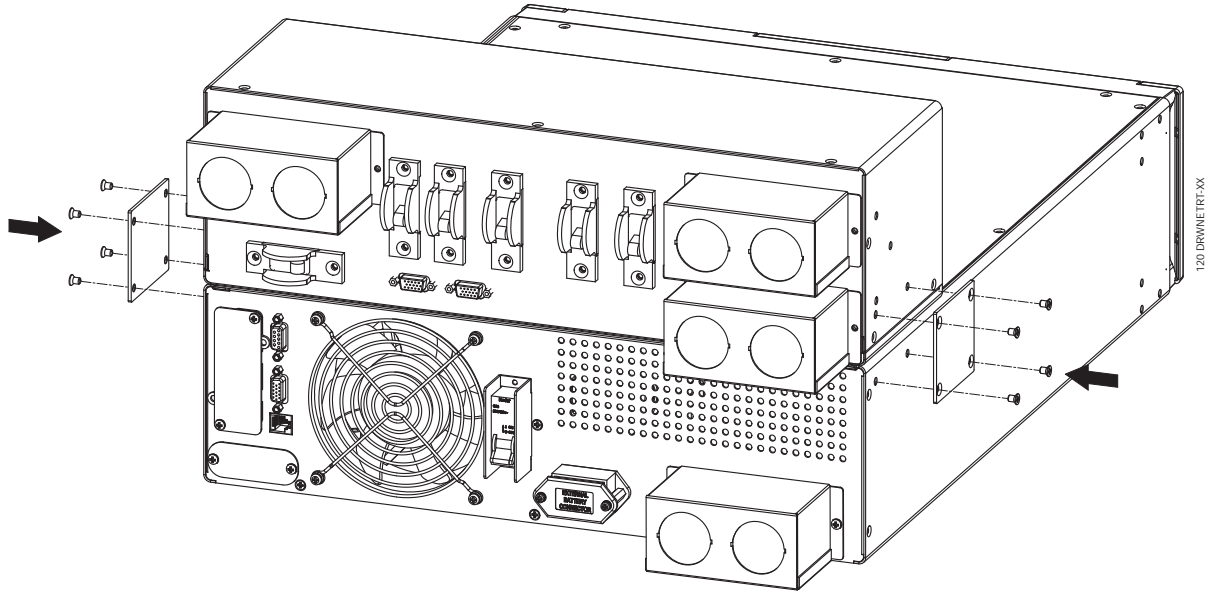

7.1.2 Fixing BY-PASS to UPS for vertical installation

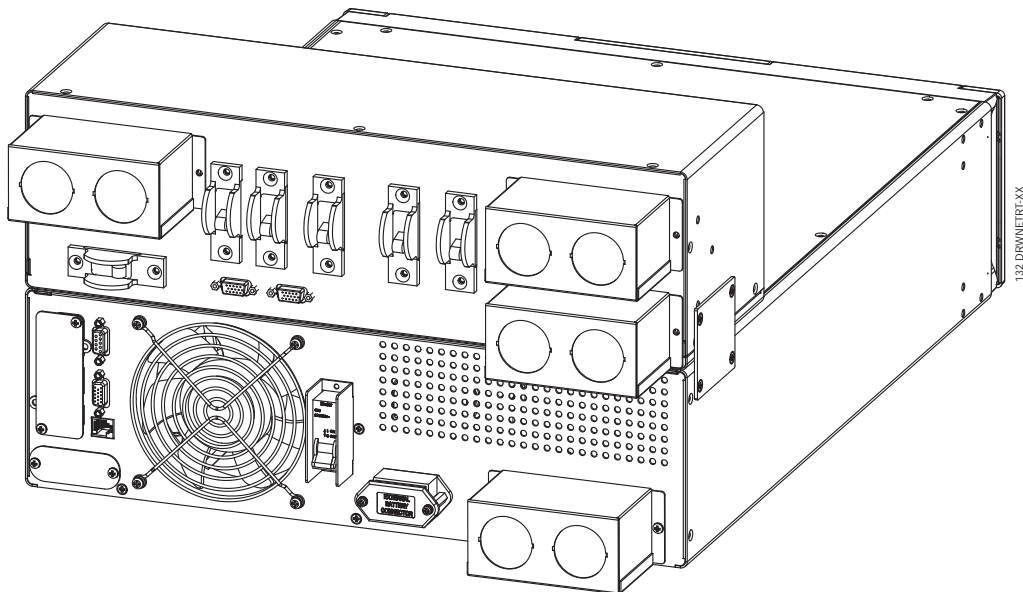

7.2 Rack installation of BY-PASS and UPS in parallel

7.2.1 Fixing brackets for rack installation

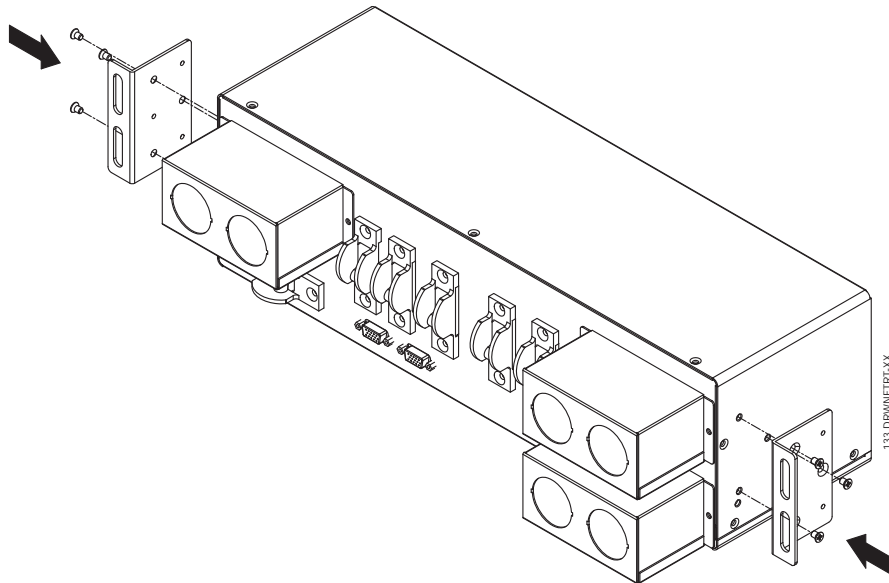

7.2.2 Fitting BY-PASS to rack

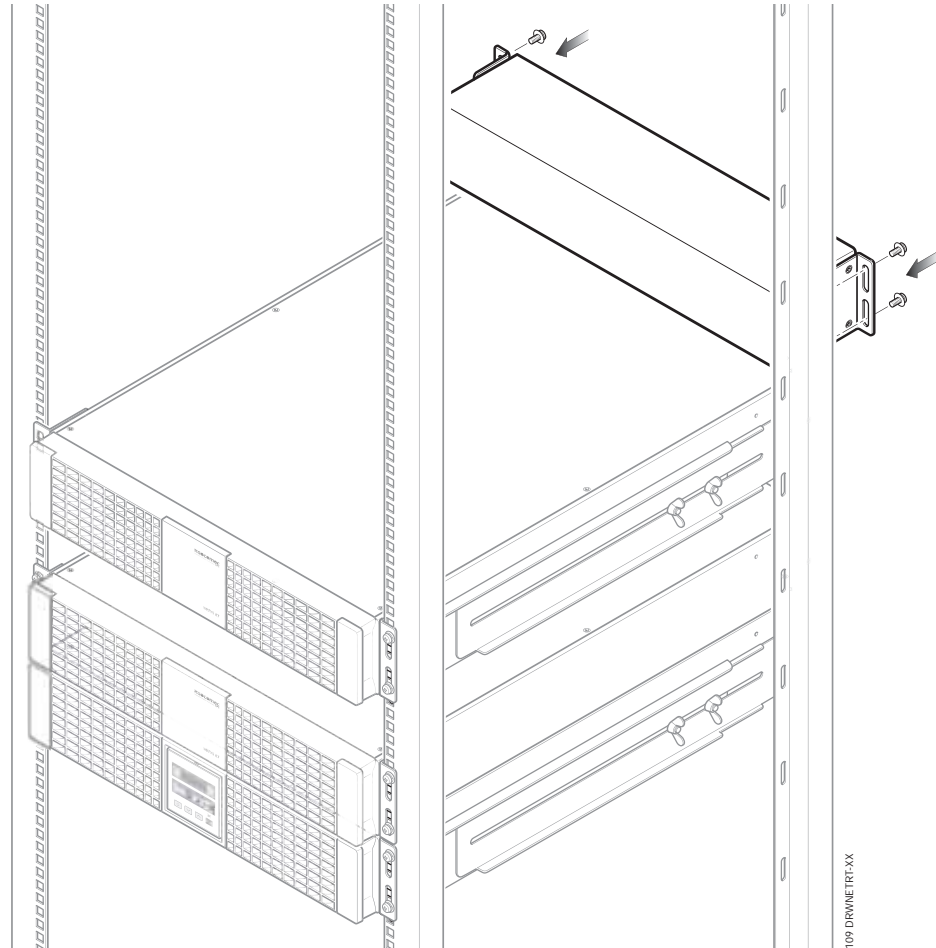

7.3 Connection of BY-PASS and UPS in parallel

7.3.1 Connection of BY-PASS to 2 UPSs

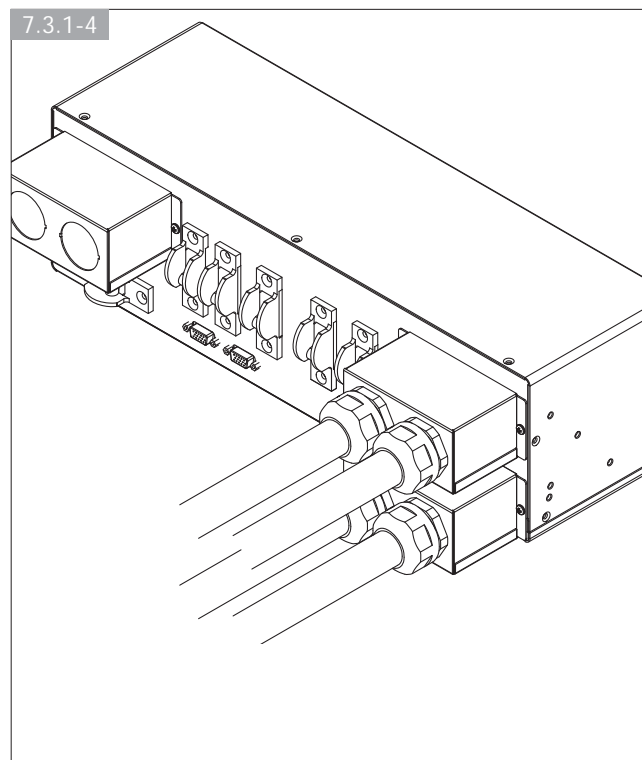
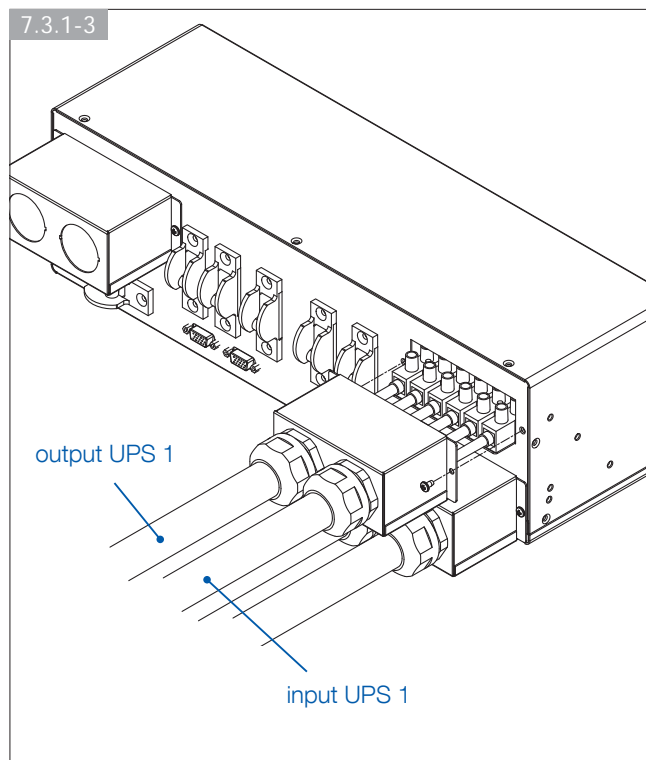
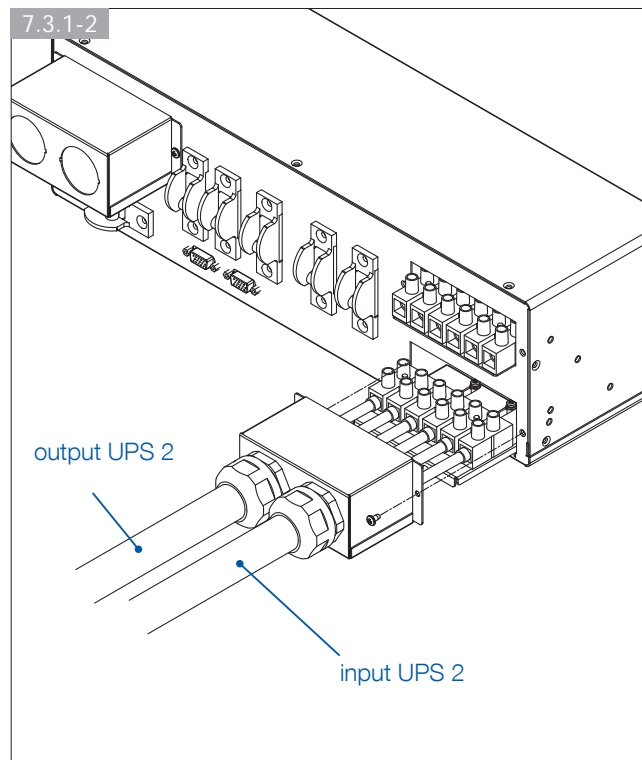
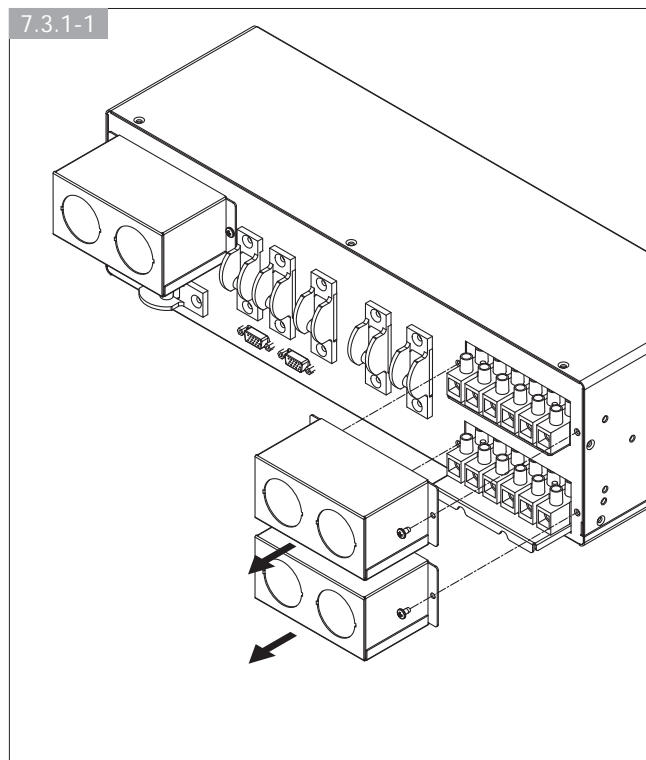

7. CONNECTION OF BY-PASS AND UPS IN PARALLEL

7.3.2 Connection of BY-PASS to line and load

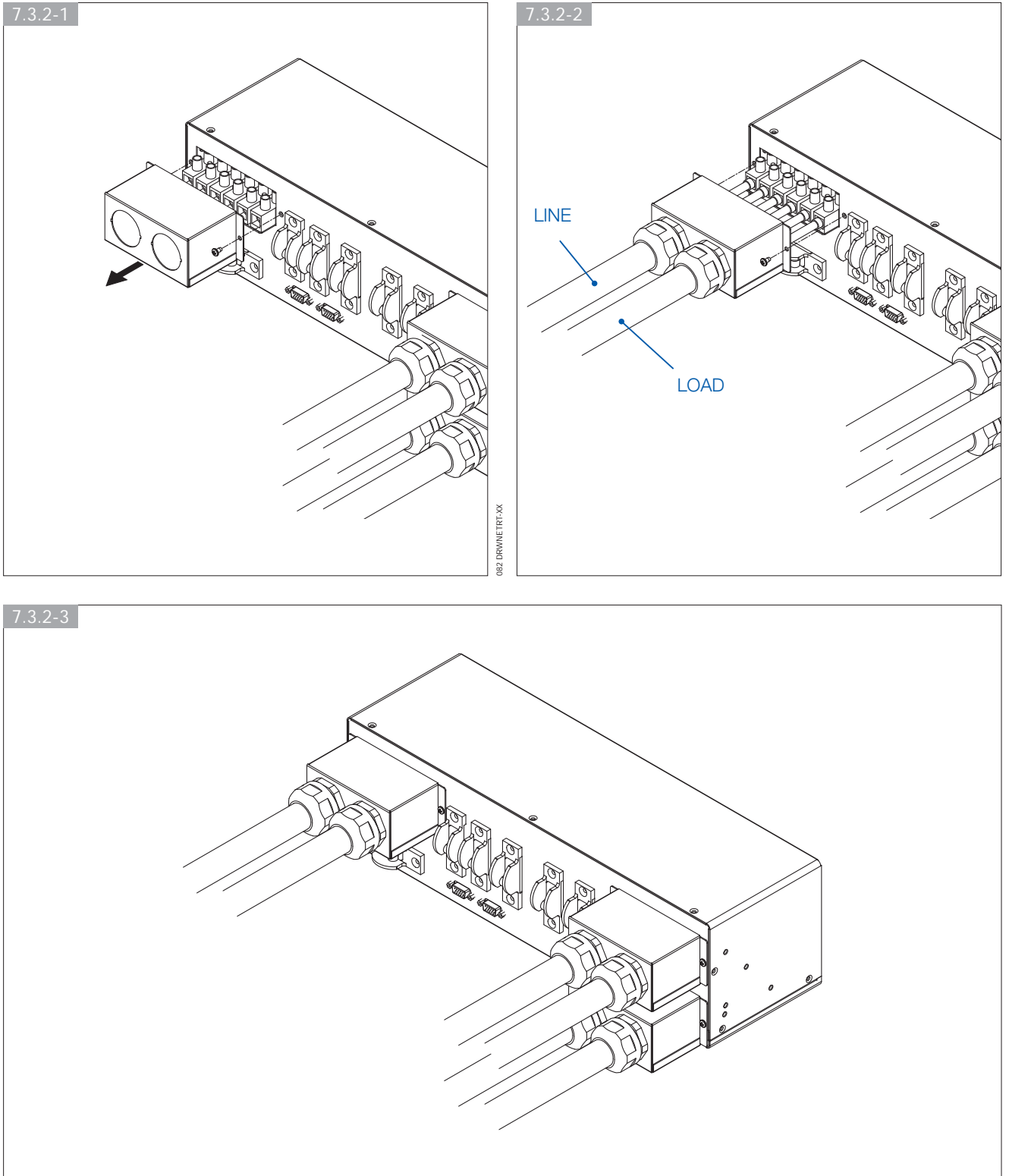

7.4 Connection of BY-PASS to UPS in parallel

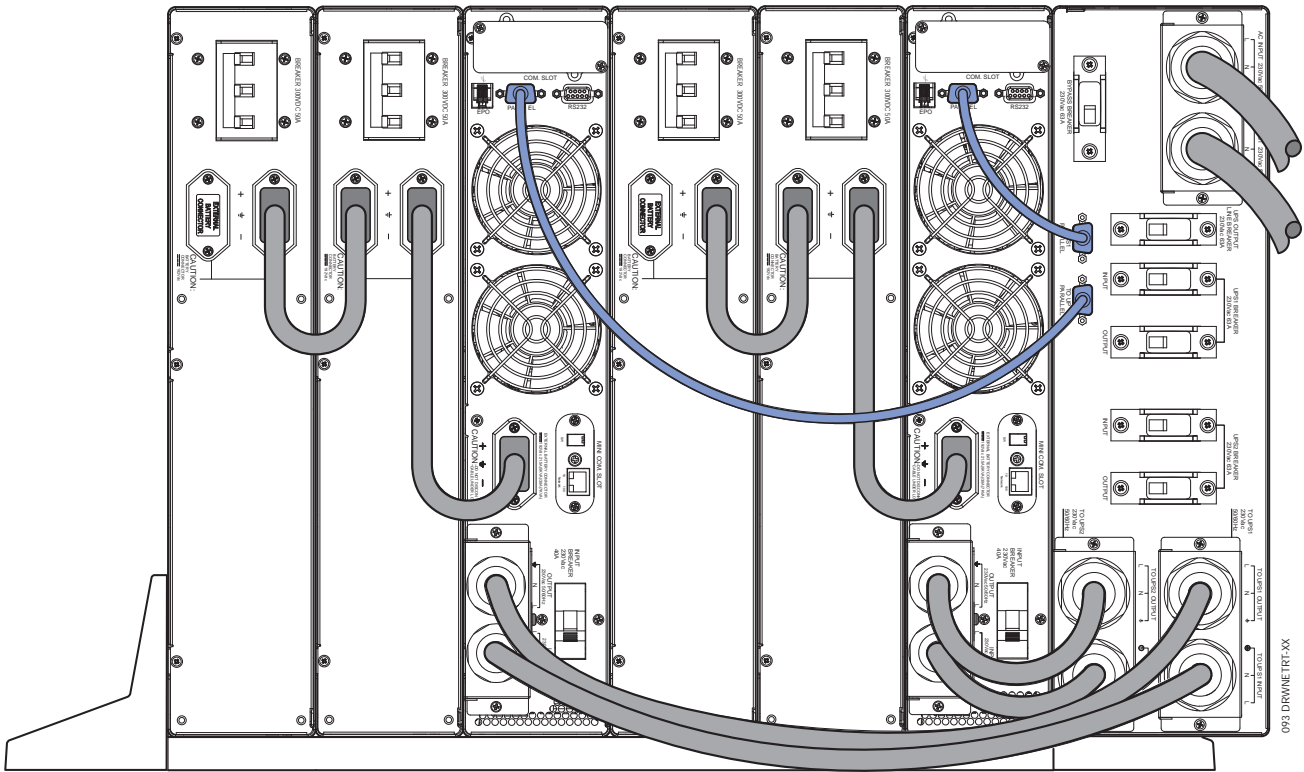

8. MIMIC PANEL

The mimic panel on the front of the UPS provides all essential information on the operating status of the appliance.

Legend

- A Display.
- B Red symbol lit.
Fault.
- C 2 colour LEDs:
• Green - Normal.
• Red - Overload.
- D Green LED lit.
Normal operation (inverter in-line).
- E Power-on, Enter and Buzzer override button.
- F Scroll button - UP
- G Scroll button - DOWN
- H Off button
- I Green LED:
• Lit - Mains healthy
• Blink - Mains low but not loss.
- L 3 colour LEDs:
• Green - Stand-alone mode (battery power)
• Yellow - Battery low.
• Red - Battery needs replacing.
- M Yellow LED:
• Lit - Operation in by-pass mode
(Bypass voltage healthy).
• Blink - Operation in by-pass mode
(Bypass voltage Out of range)

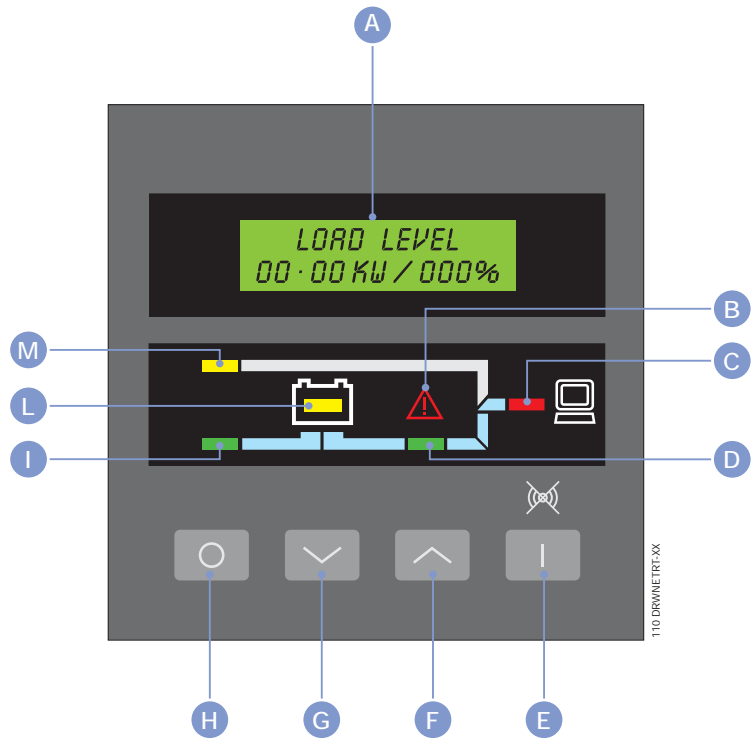

9. OPERATING MODES

9.1 Basic settings

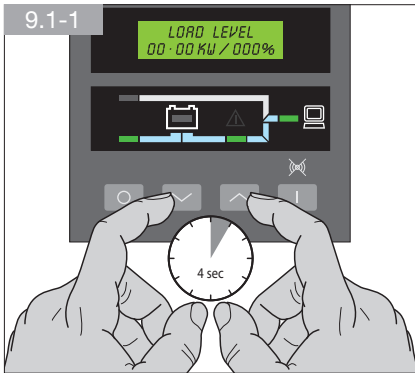

143 DRWNTRTXX

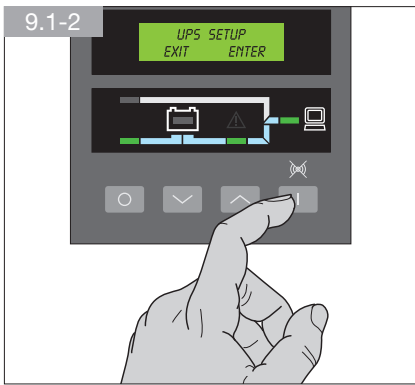

144 DRWNTRTXX

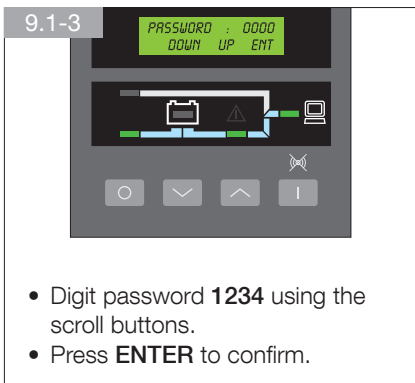

100 DRWNTRTXX

LEVEL 1	LEVEL 2	LEVEL 3	
BASIS SETTING	CHANGE PASSWORD	PASSWORD : 0000	
	LANGUAGE	ENGLISH	
		FRENCH	
		GERMAN	
		ITALIAN	
		SPANISH	
START SETTING	BATTERY START	ENABLE	
		DISABLE	
	AUTO RESTART	ENABLE	
		DISABLE	
CHARGER SETTING	CHARGER CURRENT	CURRENT : 0.7 A	
		CURRENT : 1.4 A ⁽¹⁾	
		CURRENT : 1.5 A	
		CURRENT : 3.0 A ⁽¹⁾	
		CURRENT : 3.0 A	
		CURRENT : 6.0 A ⁽¹⁾	
		CURRENT : 4.0 A	
		CURRENT : 8.0 A ⁽¹⁾	
BATTERY SETTING	BATT LOW ALARM	20%	
	SHUTDOWN VOLTAGE	SD VOLT:168VDC	
	DISCHARGE TEST	NO TEST	
		30 DAYS	
		60 DAYS	
		90 DAYS	
	BATT CABINET NUM	NUM: 1x16PCS ⁽²⁾	
		NUM: 1x20PCS ⁽³⁾	
OUTPUT SETTING	OUTPUT VOLTAGE	230 V	
		220 V	
		208 V	
		240 V	
		FREQ. CONVERTER	DISABLE
			50 HZ
			60 HZ
		ECO MODE	DISABLE
		ENABLE	

⁽¹⁾ UPS with powerful battery charger.

⁽²⁾ Netys RT 5-7 kVA.

⁽³⁾ Netys RT 9-11 kVA.

9.2 Operation in BY-PASS mode for maintenance purposes - single UPS

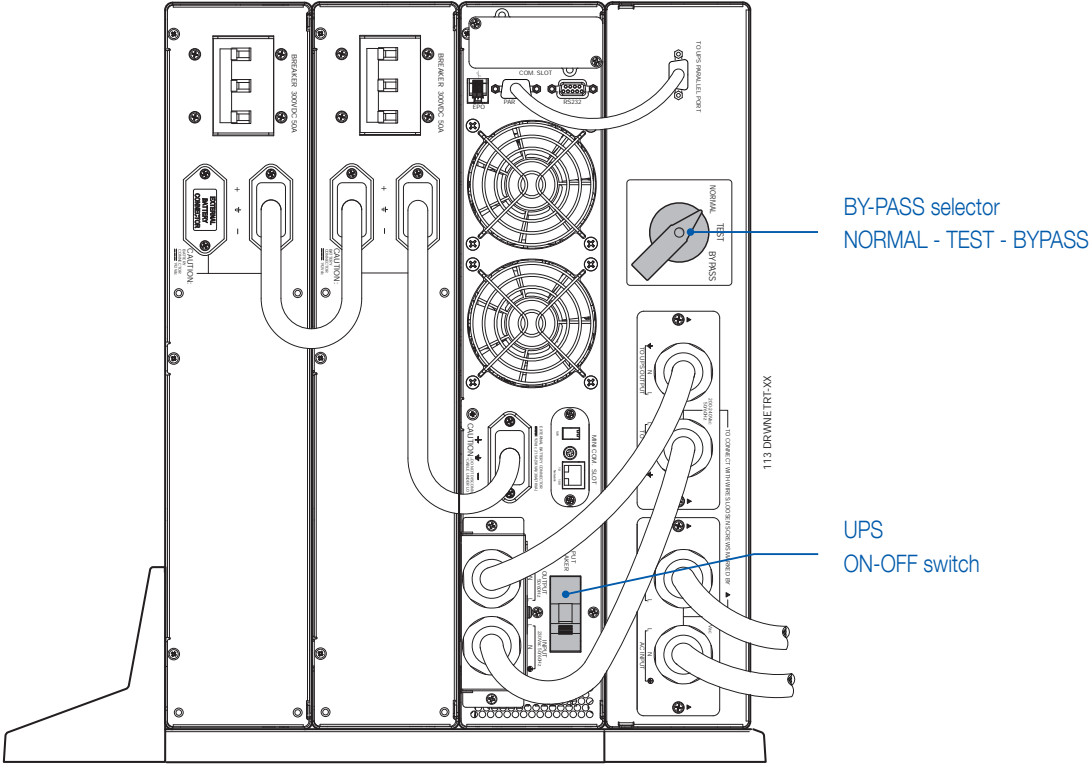

9.2.1 Activation of by-pass mode for UPS maintenance purposes

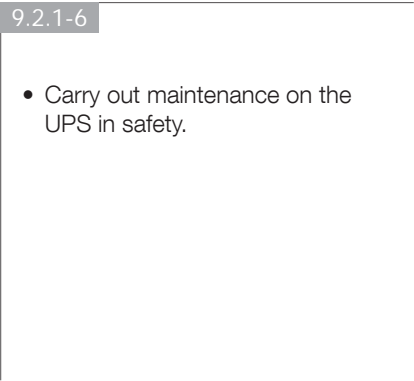
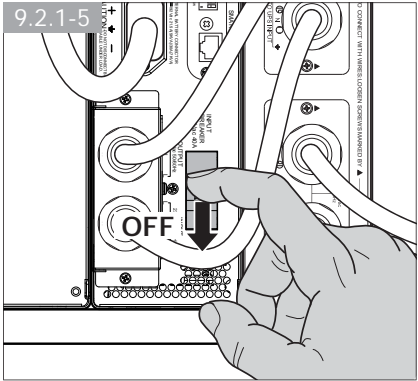
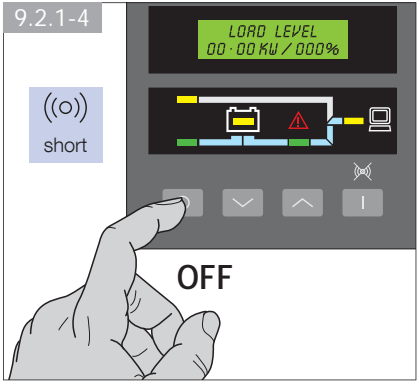
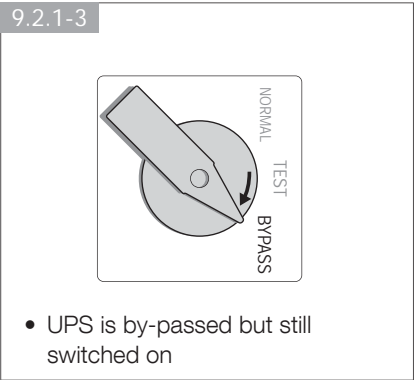
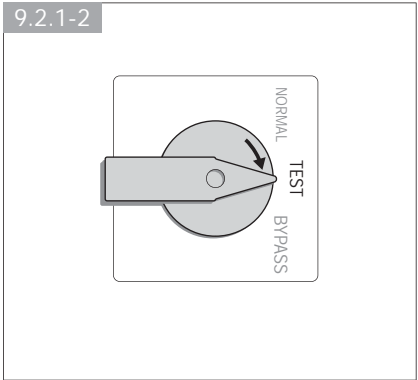
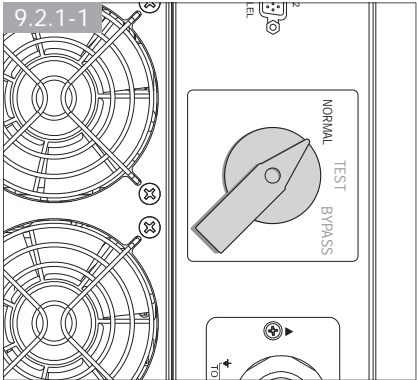

9.2.2 Restoring normal operation of UPS

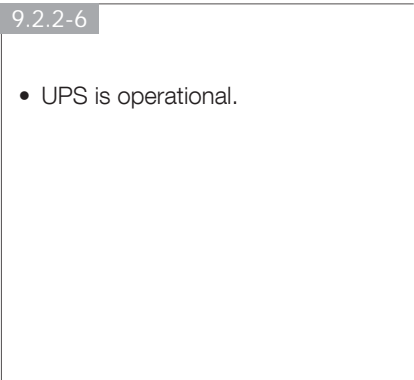
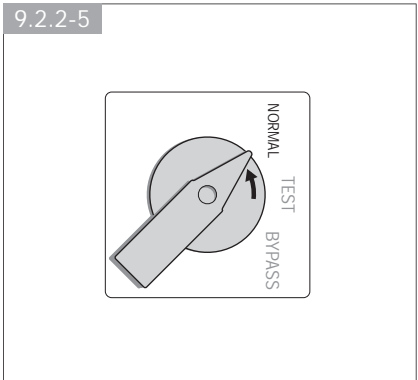
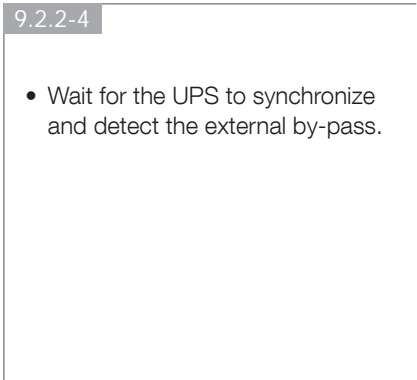
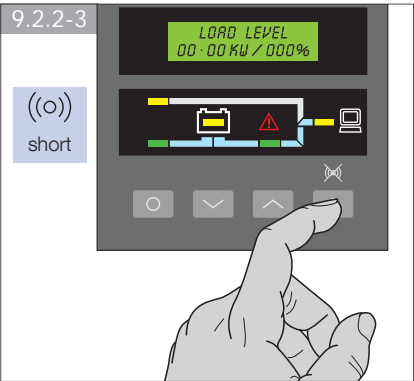
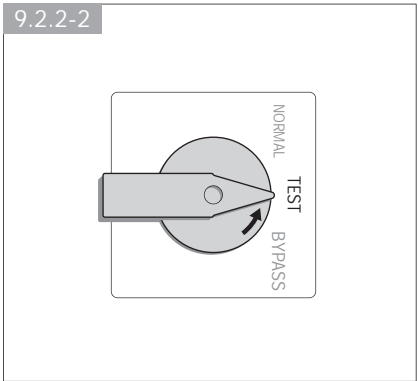
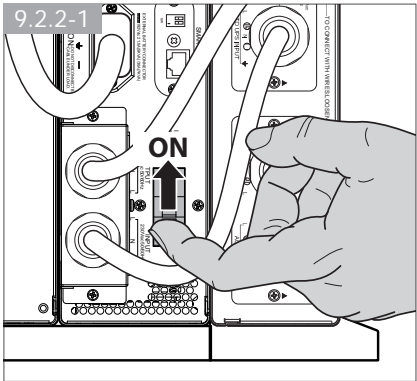

9.3 Operation in BY-PASS mode - UPS in parallel for maintenance purposes

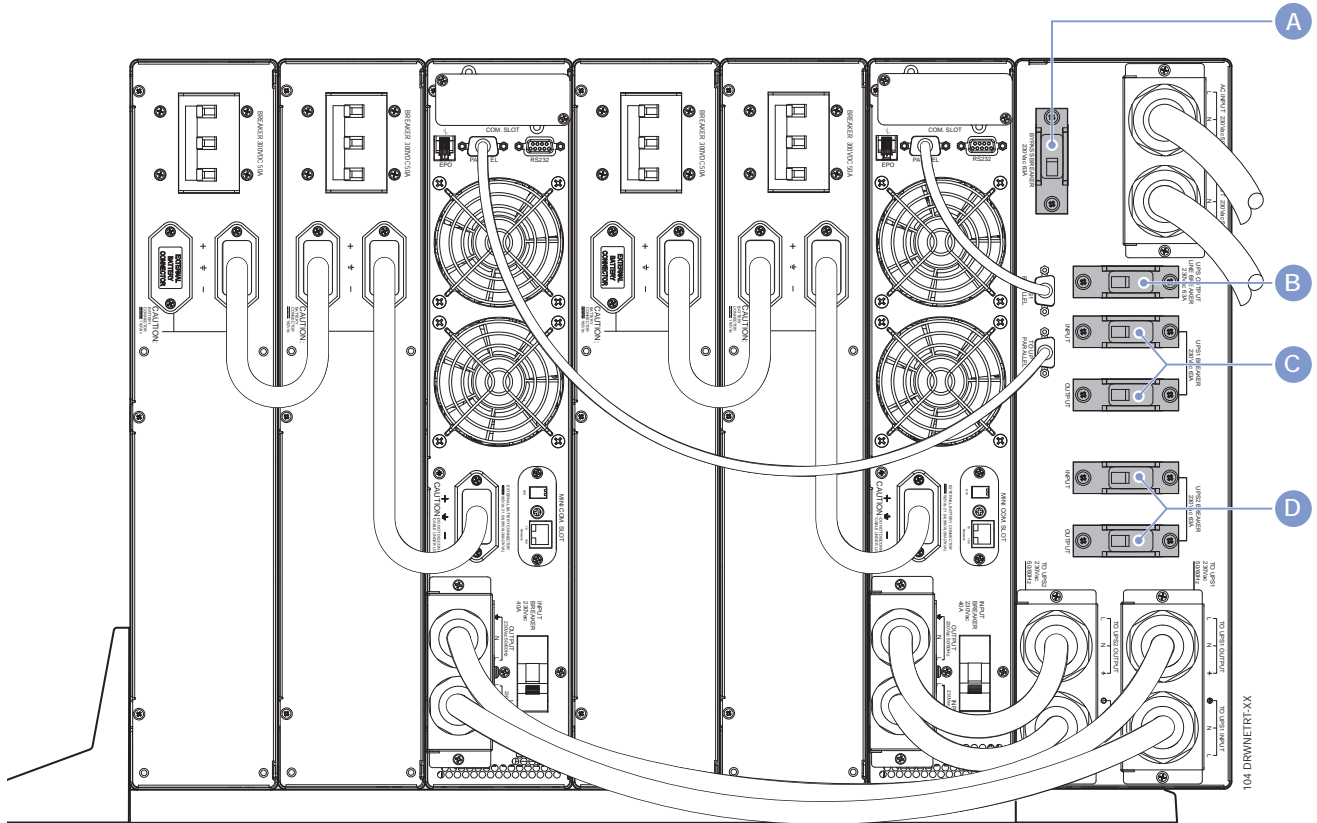

	A BYPASS switch	C UPS1 switch	D UPS2 switch	B UPS output line breaker
Output UPS1+UPS2	OFF	ON	ON	ON
Output UPS1 (UPS2 off for maintenance)	OFF	ON	OFF	ON
Output UPS2 (UPS1 off for maintenance)	OFF	OFF	ON	ON
BY-PASS Output	ON	OFF	OFF	ON

Notes:

1. The function of the UPS output line breaker is to protect the output from overloads.
2. Disconnect all cables from the UPS when carrying out maintenance work.
3. To guard against operator error, wire in a detection signal for the BY-PASS switch.
4. BY-PASS output: turn off UPS1 and UPS2 by pressing the OFF buttons

10. COMMUNICATION

Communication software and accessories are available for monitoring the status of the UPS, with the end in view of optimizing normal operation and ensuring that shutdown at the end of backup time is managed correctly. Applications allow recording of all power outages and any depletion of battery power so as to enable the activation of an automatic procedure for closing programs in ordered sequence and shutting down the system.

NETYS RT no-break systems are equipped with RS232 serial communication interface, and slots for NetVision cards.

10.1 Communication solutions

- **UniVision local management software** (RS232interface) with local shutdown functions for Windows™ and Linux systems, downloadable free of charge from the Socomec website www.socomec.com/univision (CD included with certain models).
- **Uni Vision Pro network management software** (RS232interface) with local/remote shutdown functions on major operating systems, using Java Shutdown Client.
- **Web/SNMP manager** (Web/SNMP slot card) allowing control via LAN using TCP/IP protocol, and remote shutdown management.
- **BMS** (JBUS protocol), allows the UPS to interface with a Building Management system.

10.2 RS232 interface

This interface is required to run the UniVision local management software and UniVision Pro network management software. Use the cable provided.

10.3 Integrated WEB/SNMP card

With this card installed, the UPS can be connected directly to a LAN (RJ45 ethernet) and controlled remotely from a WEB browser using TCP/IP protocol. Reference should be made to the dedicated literature for a full description of the functionalities.

10.4 Use of warning relay interface

This is an optional card (slot-mounted) that will manage 6 indication circuits with isolated contacts carrying information on the status of the UPS. The maximum voltage that can be applied to the contacts is 24 VDC, and the maximum current 500 mA.

Relay contacts can be set individually for NO (default) or NC operation, and programmed selectively for customized monitoring of the UPS.

If requested, the UPS can also be switched off utilizing a remote external shutdown contact. The command is acknowledged when the contact is made and held for 3 seconds (default), whereas the external contact must be made between the common and input pins.



The external contact MUST be dedicated and voltage-free, so as not to cause permanent damage to the UPS.

The shutdown input can be configured alternatively as a battery test input.

10.4.1 Internal circuit

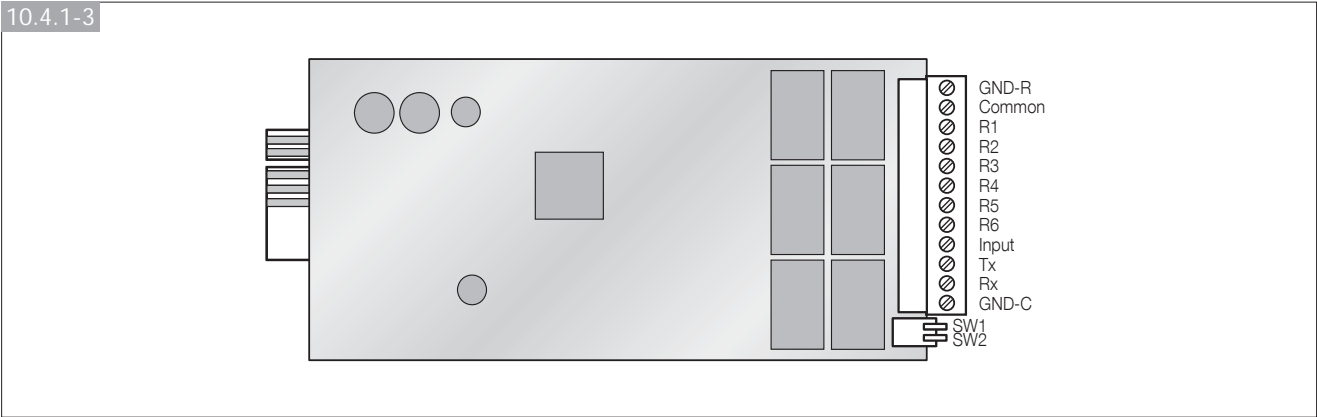
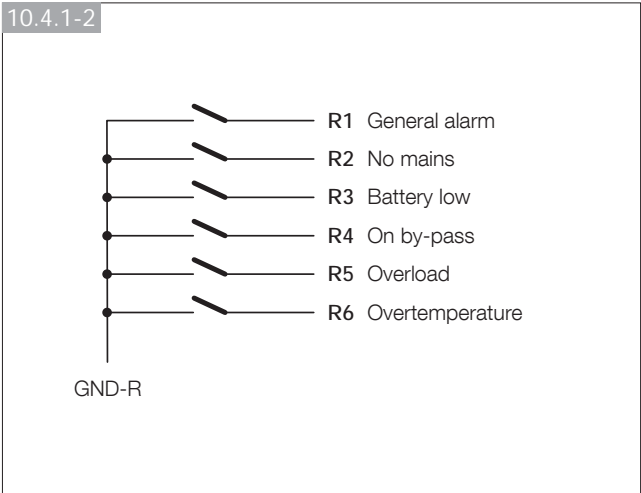
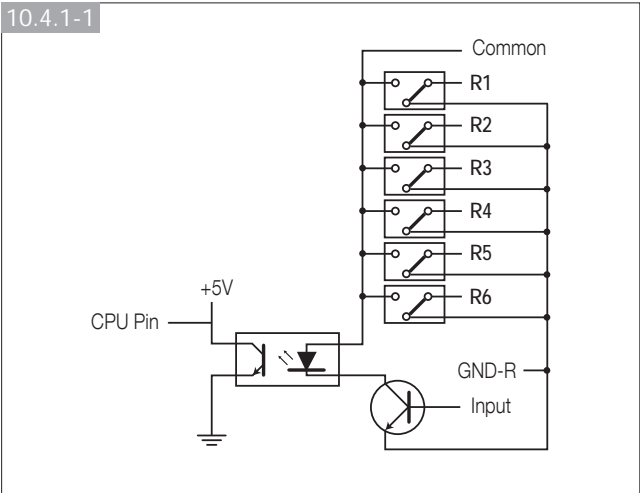

10.4.2 Standard configuration

SW1	SW2	relay contact
OFF	OFF	NO
ON	OFF	NC

GND-R: Relay ground contact	
Common: 12~24 V DC	
R1	General alarm
R2	No mains
R3	Battery low
R4	On by-pass
R5	Overload
R6	Overtemperature
Input: Remote shutdown or battery test	

10.4.3 Customized configuration for relay and/or input contacts

Connect **Tx** to pin 2, **Rx** to pin 3 and **GND-C** to pin 5 of the computer's RS232 port.

In Windows, start the Hyper-Terminal application and proceed to open the specified COM port.

Set the following properties: Baud rate: 2400, Data Bits: 8, Parity: None, Stop Bit: 1, Flow Control: None.

• Configuration.

Press <Enter> to display the main menu of the relay card.

1. Press '1' to configure the alarms relative to contacts **R1~R6** (**Customize Output Relay**).

This menu can be used to assign a customized alarm indication to contacts **R1~R6**.

Having completed the configuration, shift **SW2** to the ON position to activate the settings. The default settings can be restored by setting **SW2** to OFF.

2. Press '2' to configure the **input** signal.

The input signal can be used either to shut down the UPS or to test the batteries. The delay preceding shutdown of the UPS can be set up to 9999 seconds maximum.

3. Press '3' to configure NO or NC operation of each relay.

Shift **SW2** to the ON position to activate the settings.

If **SW2** is returned to the OFF position, **SW1** can be used to check the NO or NC position of all the relays.

4. Press '0' to end the configuration session. The system will prompt you to save the new settings.

Press 'Y' to save, 'N' to cancel.

UPS Relay Card

Firmware Version: Relay Card V1.4

- [1] . Customize Output Relay
- [2] . Configure Input Signal
- [3] . Customize Normal Open or Normal Close
- [0] . Quit

Please Enter Your Choice >

Customize Output Relay

Relay Selected Event

- [1] . Relay 1: Summary Alarm
- [2] . Relay 2: Power Fail
- [3] . Relay 3: Battery Low
- [4] . Relay 4: On by-pass
- [5] . Relay 5: Overload
- [6] . Relay 6: Overtemperature
- [0] . Back to Previous Menu

Please Enter Your Choice >

Customize Output Relay

Relay Selected Event

- [1] . Relay 1: Normal Close
- [2] . Relay 2: Normal Open
- [3] . Relay 3: Normal Close
- [4] . Relay 4: Normal Open
- [5] . Relay 5: Normal Close
- [6] . Relay 6: Normal Open
- [0] . Back to Previous Menu

Please Enter Your Choice >

Configure Input Signal

- [1] . Act as Shutdown or Test: Shutdown
- [2] . Input Signal Confirm 3 Seconds
- [3] . Delay Before Shutdown 30 Seconds
- [0] . Back to Previous Menu

Please Enter Your Choice >

11. MAINTENANCE



WARNING!

The UPS generates HAZARDOUS INTERNAL VOLTAGES. All maintenance operations should be carried out by AUTHORIZED SERVICE ENGINEERS ONLY.

- The unit will operate to its maximum capability if kept powered up round the clock (24/7); this ensures that the batteries will always be properly charged.
- If the appliance is to remain idle for any length of time, wait until the batteries are fully charged (connection to mains power supply for 8 hours continuous) before shutting the UPS down.
- Recharge the batteries for a duration of 24 hours at least every 4 weeks during the time the unit remains idle.

11.1 Minor troubleshooting



WARNING!

If problems should persist or reoccur frequently after following the procedures indicated in this section, contact the SOCOMECS UPS After Sales Service, providing a full description of the current difficulty

Problem	Possible cause	Solution
"UPS not powered up (no alarm, no LEDs alight)"	The ON/TEST button has not been pressed.	Press the ON/TEST button to switch the UPS on.
	Shutdown due to flat battery and no mains power.	Wait for mains power to be restored
	Thermal-magnetic switch on the rear panel has been tripped.	Reduce the load connected to the UPS, then reset the thermal-magnetic switch.
	Faulty UPS	Contact SOCOMECS UPS After Sales Service if the solutions indicated above do not solve the problem.
UPS does not guarantee the expected backup time.	UPS internal batteries not completely charged.	Recharge the batteries for a minimum of 8 hours.
	UPS in overload.	Disconnect non-essential loads.
	Depleted batteries.	The batteries will degrade quickly if used frequently, or in high operating temperatures. Should the batteries have reached the end of their life cycle, contact SOCOMECS UPS After Sales Service. Batteries must be replaced even if the "Replace battery" LED is not lit.
	Battery charge fault or other causes.	Contact SOCOMECS UPS After Sales Service
"Replace battery" LED lit.	Batteries flat.	Charge the batteries for a minimum of 8 hours. If the problem persists, contact SOCOMECS UPS After Sales Service to have for battery replacement.
Faulty communication between PC and UPS.	Wrong transmission speed.	Change the transmission speed and test again.
	RS232 connection incorrect.	See "Communication" section of this manual. Reconnect the UPS to the COM1/COM2 port of the PC.
	USB connection incorrect.	Reconnect the UPS to the USB port of the PC.
UPS functions in "Battery Mode" even though a.c. mains is connected and healthy.	Mains voltage not registering at UPS input.	Check the input voltage connection.
	Thermal-magnetic switch on the rear panel has been tripped.	Reduce the load connected to the UPS, then reset the thermal-magnetic switch.
	Input voltage too high, too low or distorted.	Have the mains voltage checked by a qualified electrician.
Overtemperature.	Air intake fans and fan cowl may be obstructed.	Select a well ventilated area in which to position the UPS, allowing suitable dissipation of heat.
	Ambient temperature is higher than 40 °C (104 °F).	Position the UPS in a cooler area.
"Fault" LED lit and alarm signal generated.	UPS faulty.	Contact SOCOMECS UPS After Sales Service.
"Overload" LED lit, with continuous alarm signal.	Overload.	Disconnect non-essential loads.

12. TECHNICAL SPECIFICATIONS

Models	NRT-U5000	NRT-U7000	NRT-U9000	NRT-U11000
UPS power	5000 VA 3500 W	7000 VA 4900 W	9000 VA 6400 W	11000 VA 8000 W
Input	Single-phase 230 V (160-275 V); 50/60 Hz with automatic selection			
Input socket	Terminals			
Output	Single-phase 230 V nominal $\pm 2\%$ (selectable: 200/208/220/240 V); 50/60 Hz			
Output sockets	Terminals			
Technology	On-line double conversion (VFI-SS-111)			
Online efficiency	up to 92%			

Batteries				
Type	Maintenance-free sealed lead - life expectancy 3-5 years			
Typical backup ⁽¹⁾	10 minutes	7 minutes	12 minutes	8 minutes

Communication				
Connection interface	RJ 45 and RS 232 ports and slots for communication cards			
Ethernet	WEB / SNMP interface (Optional)			

Environment				
Dimensions WxDxH	440x670.5x88.7 mm 17,3"x26,4"x2U		440x623x130.6 mm 17,3"x24,5"x3U	
Weight	15 kg	15.5 kg	19.5 kg	20 kg
Reference standards	EN 62040-1-1, EN 62040-2 ⁽²⁾ , EN 62040-3, EN 61000-4-5/C62.41:1991 (Overvoltage)			

⁽¹⁾ With battery module included.

⁽²⁾ With output cables shorter than 10 m.



Socomec UPS worldwide

IN EUROPE

BELGIUM

Schaatsstraat, 30 rue du Patinage
B - 1190 Bruxelles
Tel. +32 (0)2 340 02 34
Fax +32 (0)2 346 16 69
be.ups.sales@socomec.com

FRANCE

95, rue Pierre Grange
F - 94132 Fontenay-sous-Bois Cedex
Tel. +33 (0)1 45 14 63 90
Fax +33 (0)1 48 77 31 12
ups.paris.dcm@socomec.com

GERMANY

Heppenheimerstraße 57
D - 68309 Mannheim
Tel. +49 (0) 621 71 68 40
Fax +49 (0) 621 71 68 44 4
de.ups.all@socomec.com

ITALY

Via Leone Tolstoj, 73 - Zivido
20098 San Giuliano Milanese (MI)
Tel. +39 02 98 242 942
Fax +39 02 98 240 723
siconmi@socomec.com

NETHERLANDS

Bergveste 2F
NL - 3992DE Houten
Tel. +31 (0)30 63 71 504
Fax +31 (0)30 63 72 166
nl.ups.sales@socomec.com

POLAND

Nowowiejska St 21/25
00-665 Warszawa
Tel. +48 (0)22 2345 223
Fax +48 (0)22 2345 223
ups.poland@socomec.com

PORTUGAL

Rua Moinho do Cuco
Bloco A
Lj. Dta. - Paz
2640-566 MAFRA
Tel. +351 261 812 599
Fax +351 261 812 570
portugal@socomec.com

RUSSIA

Kutuzovsky pr. 13, 44-45
121248 - Moscow
Tel. +7 495 775 19 85
Fax +7 495 775 19 85
ups.russia@socomec.com

SLOVENIA

Savlje 89
SI - 1000 Ljubljana
Tel. +386 1 5807 860
Fax +386 1 5611 173
si.ups.info@socomec.com

SPAIN

C/Nord, 22 Pol. Ind. Buvisa
E - 08329 Teià (Barcelona)
Tel. +34 935 407 575
Fax +34 935 407 576
info@socomec-aron.com

UNITED KINGDOM

Units 7-9 Lakeside Business Park
Broadway Lane - South Cerney
Cirencester - GL7 5XL
Tel. +44 (0)1285 863300
Fax +44 (0)1285 862304
uk.ups.sales@socomec.com

IN ASIA

CHINA

No.1 Yuanda Road Haidian District, Beijing, 100097
Golden Resource Times Shopping Mall
No. 1001 section B the 2nd issue of business building
Tel. +86 10 8889 2202
Fax +86 10 8889 2150
socomec@socomec.com.cn

INDIA

B1, IInd Floor, Thiru-Vi-Ka-Industrial Estate
Guindy
Chennai - 600 032
Tel. +91 44 3921 5400
Fax +91 44 3921 5450 — 51
sales@socomec-ups.co.in

MALAYSIA

31 Jalan SS 25/41- Mayang Industrial Park
47301 Petaling Jaya - Selangor, Malaysia
Tel. +603 7804 1153
Fax +603 7803 8901
sales@cspm.com.my

SINGAPORE

31 Ubi Road 1, Aztech Building
01-00 (Annex) - SG - Singapore 408694
Tel. +65 6745 7555
Fax +65 6458 7377
sg.ups.sales@socomec.com

THAILAND

No.9 Soi Vibhavadirangsit 42
Vibhavadirangsit Rd, Ladyao
Chatujak Bangkok 10900
Tel. +66 2 941-1644-7
Fax. +66 2 941-1650
info@socomec-th.com

HEAD OFFICE

SOCOMECE GROUP

S.A. SOCOMECE capital 11 102 300 € - R.C.S. Strasbourg B 548 500 149
B.P. 60010 - 1, rue de Westhouse - F-67235 Benfeld Cedex

SOCOMECE UPS Strasbourg

11, route de Strasbourg - B.P. 10050 - F-67235 Huttenheim Cedex- FRANCE
Tel. +33 (0)3 88 57 45 45 - Fax +33 (0)3 88 74 07 90

SOCOMECE UPS Isola Vicentina

Via Sila, 1/3 - I - 36033 Isola Vicentina (VI) - ITALY
Tel. +39 0444 598611 - Fax +39 0444 598622
info.it.ups@socomec.com

SALES, MARKETING AND SERVICE MANAGEMENT

SOCOMECE UPS Paris

95, rue Pierre Grange
F-94132 Fontenay-sous-Bois Cedex - FRANCE
Tel. +33 (0)1 45 14 63 90 - Fax +33 (0)1 48 77 31 12
ups.paris.dcm@socomec.com



IOMNETRTXX01-GB 01 08.2009

www.socomec.com

Non contractual document. © 2008, Socomec SA. All rights reserved.



socomec
Innovative Power Solutions **UPS**