

Smart-house Dimmer

Power dimmer up to 500W

Type SH2D500W230

CARLO GAVAZZI



- Universal dimmer switch for R, L, C up to 500W and LED loads
- Automatic load detection for L, R, C loads
- Integrated heat sink for temperature dissipation
- 1 dimmable output
- Addressing via BGP-COD-BAT
- 2 DIN housing
- Soft start/stop
- Protected against short circuit, overload and high temperature
- Minimum load 3 W

Product Description

This 500W universal dimmer is designed for DIN-rail mounting and is 2 DIN wide. This universal dimmer is suitable for dimming resistive, inductive and capacitive loads and LED lamps (see LED lamps table). The maximum connected load is 500W depending on the temperature: the reduction is described according to the trend in "derating curve". The dimmer automatically detects if the connected load is resistive, capacitive or inductive, but if a LED lamp is to be driven, the user has to select the right curve as described below.

The dimmer is provided with memory for the last selected scenario.

The technology used enables to electrically protect the dimmer against short circuit, overload and over-temperature. Thanks to the internal bus, it can be easily connected to adjacent dimmers (see "wiring diagram") without the need of cabling the Dupline BUS.

Furthermore, the integrated sink allows you to mount the dimmers adjacently without any reduction of the load due to the increased temperature.

Ordering Key

S H 2 D 500W 230

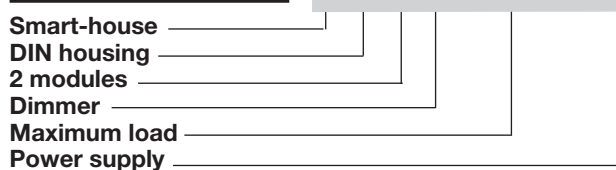

Type Selection

Housing	Mounting	Max. load	Output type	Supply: 115 to 230 VAC
2 DIN	DIN-rail	500W	Power mosfet	SH2D500W230

Output Specifications

Maximum load Note: this is the maximum power supplied to the load: if an inductive transformer is used, the efficiency of about 60% has to be considered before connecting the lamps. If a capacitive transformer is used, the efficiency is about 90%.	500 W	Dimming speed Types of dimmable lamps Different types of outputs (L,C) can not be mixed	Programmable Incandescent (R) LV halogen lamps with electronic ballast (C) LV halogen lamps with conventional transformer (L) HV halogen lamps (R) 115/230V dimmable LED lamp ESL (Electron Stimulated Luminescence) lamps
Minimum load	3 W @ 230 V, 6 W @ 115V	Notes: if energy saving lamps are used, attention has to be paid to the maximum inrush current at start-up: it must not be greater than 3.5A otherwise the overload protection will be activated.	
Protections	Overload, short circuit, thermal		
Output type	Power mosfet		
Rated operational voltage	115/240 VAC		
Operational voltage range	90 to 260 VAC		
Rated operational frequency	50/60 Hz		

Input Specifications

Key Pad	One push button on local dimmer
----------------	---------------------------------

Dupline Output Specifications

Voltage	8.2 V
Maximum dupline voltage	10 V
Minimum dupline voltage	4.5 V
Maximum dupline current	2 mA

Supply Specifications

Power supply	Overvoltage cat. II (IEC 60664-1, par. 4.3.3.2)
Rated operational voltage	115/240 VAC
Operational voltage range	90 to 260 VAC
Rated impulse voltage	2.5 kV
Rated operational power	1 W
Connection	6 x 6 mm ²
Power on delay	Typ. 2 s

General Specifications

Installation category	Cat. II	Connection	Terminal	6 Screw-type
Dielectric strength Power supply to Dupline and Dupline to Output	4 KV AC for 1 min. 6 KV impulse 1.2/50 s (IEC60664-1, TAB. A.1)	Cable cross-section	6 Screw-type	max. 6 mm ² , min. 0,5 mm ²
Channel Programming	By BGP-COD-BAT and special cable GAP-THL-CAB	Tightening torque	6 Screw-type	0.4 Nm / 1 Nm
Fail-safe mode	In case of interruption of the smart-house connection, the light will be switched ON at the memorized level or it will be switched OFF according to the status programmed with BGP-COD-BAT. Fail-safe bit = 0 (default condition) memory of the previous state. Fail-safe bit = 1 output OFF	Housing	Dimensions	2 DIN module
Environment		Material	Material	Noryl
Degree of protection		Weight	Weight	150 g
Front	IP 50	CE Marking	CE Marking	Yes
Screw terminal	IP 20	EMC	Immunity	EN 61000-6-2
Pollution degree	2 (IEC 60664-1, par. 4.6.2)	- Electrostatic discharge	- Electrostatic discharge	EN 61000-4-2
Operating temperature	-20° to +50°C (-4° to 122°F)	- Radiated radiofrequency	- Radiated radiofrequency	EN 61000-4-3
Storage temperature	-50° to +85°C (-58° to 185°F)	- Burst immunity	- Burst immunity	EN 61000-4-4
Humidity (non-condensing)	20 to 80% RH	- Surge	- Surge	EN 61000-4-5
LED's indication		- Conducted radio frequency	- Conducted radio frequency	EN 61000-4-6
Unlock	1 green	- Power frequency magnetic fields	- Power frequency magnetic fields	EN 61000-4-8
Dupline status	1 yellow	- Voltage dips, variations, interruptions	- Voltage dips, variations, interruptions	EN 61000-4-11
Output status	1 red	Emission	Emission	EN 61000-6-3
		- Conducted and radiated emissions	- Conducted and radiated emissions	CISPR 22 (EN55022), cl. B
		- Conducted emissions	- Conducted emissions	CISPR 16-2-1 (EN55016-2-1)
		- Radiated emissions	- Radiated emissions	CISPR 16-2-3 (EN55016-2-3)

Mode of Operation

Push button

The push button can be used with a short or long pulse (>2 seconds) and its behavior is the same of channel1.

Short pulse: the light is switched ON/ OFF (toggle function) with the set value. Factory settings is 100%, so the first time this push button is pressed with a short pulse, the light is switched ON to 100%. If a different light scene is memorised in the module, the light is

switched ON at that level.

Long pulse: once the light is ON, by keeping the key pressed for more than 2 seconds, the light will be increased up to 100% and then decreased down to 5%. This will be repeated until the key is kept pressed. Every time the button is pressed, the ramp is inverted. The push button is also used to enable/disable the programming access (see below).

Coding

With the BGP-COD-BAT programming unit, each switching channel can be assigned any address between A1 and P8: this is retained permanently, but may be overwritten at any time. To access the pins for programming, open the cover on the front of the dimmer module (see fig. on the left).

Pay attention to connect the BGP-COD-BAT without supply voltage on the dimmer.



Mode of Operation (cont.)

The allocation of the channels is as follows:

I/O Channel	Description
1	ON/OFF/Dimming
2	Light scene 1 (3)
3	Light scene 2 (4)
4	Dimmer output status
5	OFF
6	LED curves
7	Soft start/stop speed
8	Dimming speed

Functions which are not required should remain uncoded. The dimmer output is configured in such a way at the factory that it will be switched off in case of a fault.

Functions and programming

The dimmer is programmed with the BGP-COD-BAT programming unit. Up to 8 addresses can be programmed, (IN/OUT 1-3 of the BGP-COD-BAT) are dedicated to control the dimmer itself (light level) - see the following table "Channel Programming".

One address (IN/OUT 4 of the BGP-COD-BAT) is the output signal on the bus and indicates if the dimmer is active. The addresses are selected in the configuration software as push button channels. Address 6, 7 and 8 are special functions and are described below.

The light levels 3 and 4 can be programmed by combining 2 addresses.

With the second to last combination (only channel 5 active) the user switches the load OFF.

The shown values are factory settings and are consequently protected against accidental resetting. Nevertheless, it is possible to disable the protection to change the default values. The following steps 1-4 explain how the protection can be disabled, the values changed, the protection reestablished and default settings restored.

1. Programming access (Unlock)

- When the output is OFF, keep the push button pressed for 10 seconds.
- When the green LED will be flashing the programming access is open.

2. New light level

- Open for the programming access according to 1. Programming access.
- Use address 1 to set the required light level.
- Activate, for approx. 3 seconds, the address to which the chosen light level is to be allocated.
- When the light starts dimming fast up to 100%, down to 5% and back to actual value, the new light level is stored. Undesirable changes of the programmed parameters can be avoided by re-establishment of the programming protection - see 3. Protection.

3. Protection (Lock)

- When the output is OFF, keep the push button pressed for 10 seconds. When the green LED is always ON, the programming access is closed.

4. Restoring of factory settings

- Open for the programming access according to 1. Programming access.
- Activate address 1, 2 and 3 for approx. 9 seconds.
- When the light starts dimming fast up to 100%, down to 5% and back to the actual value, the factory settings are restored. When the factory settings are restored the programming protection is not active.

Channel 6 programming

According to the LED lamps used, the right curve has to be selected following the table "LED curve selection". If a resistive, inductive or capacitive load is used, channel 6 must not be programmed.

Advanced settings

A "switch off" function has been added on channel 5, so that the dimmer can be switched off directly from the master function without using logic programming in the smart-house controller. In addition, the ramp time (soft start/stop and dimming speed) has been made adjustable, so that each of these two functions can be set to four additional ramp times (apart from the default times). This can be done individually for each type of ramp. If other ramp times are desired, these are set by means of the channels 7 and 8 (See tables below).

Soft start/stop	
Ch.7	0-100% (seconds)
-	2
P1	4 (standard)
P2	8
P3	16
P4	32

Dimming	
Ch.8	0-100% (seconds)
-	1.8 (standard)
P1	3.6
P2	7.2
P3	14.4
P4	26.7

This means that if a start/stop ramp time of 8 secs is desired, then channel 7 is set to P2. The

addresses P1-P4 can, of course, be used for any other purpose, since they are only used to state ramp times.

Hardware short circuit protection

As described in the "Lighting Circuit Design", if more capacitive transformers have to be connected in parallel for a total load higher than 180W @20°, the hardware short circuit protection has to be disabled.

To disable this protection, keep the pushbutton pressed during the power up of the dimmer: after two seconds the green LED will start blinking according to what is described in paragraph "LED indications". If the hardware short circuit protection is enabled, it is always active when the output is both on and off. If the protection is disabled, it is active only when the load is off, in this situation care have to be taken to avoid short circuits when the output is active, otherwise the dimmer will be damaged.

Channel programming

Channel combination				Activation	
1	2	3	5	Short	Long
				ON/OFF	Dimming UP/DOWN, 5%..100%
				Light scene #1 (40%)	Store light scene #1
				Light scene #2 (80%)	Store light scene #2
				Light scene #3 (20%)	Store light scene #3
				Light scene #4 (60%)	Store light scene #4
				100%	
				OFF	OFF
				0% / OFF (0%)	Set light scene back to factory settings

(*)Factory settings

LED Lamp Dimming

When using the SH2D500W230 dimmer with LED lamps, channel 6 needs to be programmed with address P1 when the LED manufacturer recommends trailing edge dimming (capacitive) or P2 when the LED manufacturer recommends leading edge dimming (inductive). The selection of P1 or P2 also implements a different response curve. This curve is the relationship between lamp brightness and the power supplied to it. LED lamps have a different curve compared to standard inductive loads.

If channel 6 is given a blank

address, automatic load detection and the standard curve are restored.

Please see table here for manufacturer's recommendation. If your LED lamp is not listed, please refer to the manufacturer for advice on their preference for leading or trailing edge dimming.

If many LED lamps are connected in parallel, we suggest the following rule to define the maximum number of LED lamps, the maximum total LED lamp power $\leq 1/10$ th of dimmer's maximum rated power. The maximum load depends on the capacitive input impedance of the LED lamps, so it can

vary according to the LED lamps type.

If the red LED on the SH2D500W230 dimmer starts blinking continuously as soon as the load is applied, this suggests that the total load has become more capacitive than inductive (the total capacitance is done by the sum of the capacitance of each connected LED lamp) and can not be driven anymore by setting channel 6 to P2.

The explanation of this is as follows, as previously described most LED lamps have to be dimmed as an inductive load with leading edge dimming (P2), but if

more LED lamps are connected in parallel, the load becomes more capacitive (total capacitance is the sum of capacitance for each connected).

Since a capacitive load can not be dimmed with leading edge dimming (because of the currents peaks) channel 6 has to be set trailing edge dimming (P1). In this situation the dimming performance may be reduced.

A compromise between dimming performance and the total load that can be connected has to be decided by the installer.

LED curve selection

www.productselection.net/manuals/uk/led_curve_selection.pdf

LEDs Indication

Red LED: Always ON: Load ON, no error

- 1 short blink every 4 seconds: High current warning ($> 2.5A$). The dimmer goes on working but high temperature might occur. This depends on the time the output stays on and on the room temperature.

- 2 short blinks every 4 seconds: Overvoltage error. To reset it, switch the dimmer OFF. If the error appears again, the load must be modified.

- 3 short blinks every 4 seconds: High temperature error: this error will be triggered if the internal temperature raises above $90^{\circ}C$. Please wait until the inside temperature goes below $70^{\circ}C$. The reset of the error

is automatic once the temperature is within operating range.

- 4 short blinks every 4 seconds: Wrong frequency error. If the frequency of the power supply is correct, this error indicates a hardware failure. The reset of the error is automatic once the frequency is ok.

- 5 short blinks every 4 seconds: Short circuit software protection active. As soon as the dimmer detects the short circuit, it starts counting a timeout of 30 seconds during which you have to wait. Once this timeout is elapsed, the green LED blinks synchronously with the red one: at this point, reset the error by removing the short circuit

and press the push button on the dimmer.

If the error is still present, the above procedure should be repeated.

Always blinking: Hardware short circuit protection active. To reset it, switch the dimmer OFF, remove the short circuit and switch the dimmer ON again.

Green LED: Always ON: Hardware short circuit protection active, lock condition

- 1 short blink every 2 seconds: Hardware short circuit protection disabled, lock condition

- 2 short blinks every 2 seconds: Hardware short circuit protection disabled, unlock condition

- 3 short blinks every 2 seconds: Hardware short circuit protection enabled, unlock condition

- 5 short blinks every 4 seconds: software short circuit protection active (this visualization overwrites the previous ones).

Yellow LED: if the Dupline Bus is working properly, it is always ON.

If there is a fault on the Bus it will be flashing.

It is OFF if the Bus is OFF or not connected.

Lighting Circuit Design

Some general rules have to be taken into consideration when designing lighting circuits.

Ferromagnetic transformers: When using halogen lighting with ferromagnetic transformers, pay attention to the output of the transformers. To maximise efficiency, load these transformers with at least 80% of their normal power. Pay attention to the output of the transformer when determining the total load of the dimmer. The transformer has to be suitable for dimming.

Electronic transformers: Electronic transformers present a capacitive load to the dimmer but if the cable between the transformer and the dimmer is significant this will introduce an additional inductive load, and the dimmer would see a combination of the two types of load (inductive and capacitive). It is recommended that an electronic transformer is loaded to at least 75% of its maximum rated loading, this reduces the possibility of lamp flicker when dimming, as is common with electronic transformers. Refer to the manufacturer's specifications for the electronic trans-

former being used. Pay attention to the output of the transformer when determining the total load of the dimmer (average efficiency is around 90%). The transformer has to be suitable for dimming. When a capacitive load is initially connected there may be a substantial surge of current through the primary winding called the inrush current. This inrush current may last for 2-3 seconds and can have a peak of 10 times the RMS current stated by the manufacturer of the transformer (this is also valid for CFL fittings). If many electronic transform-

ers are connected in parallel, the value of the total current is given by the sum of the current peaks generated by each transformer. If the total inrush current is higher than 3.5 A, the dimmer's hardware short circuit protection will be activated. As a general rule if the short circuit protection is enabled, a total load of 30% of the nominal dimmer output power can be connected to the dimmer (180W@20°C). If the short circuit protection is disabled, a total load of 90% of the nominal dimmer output power can be connected (540W@20°C).

Derating Curve

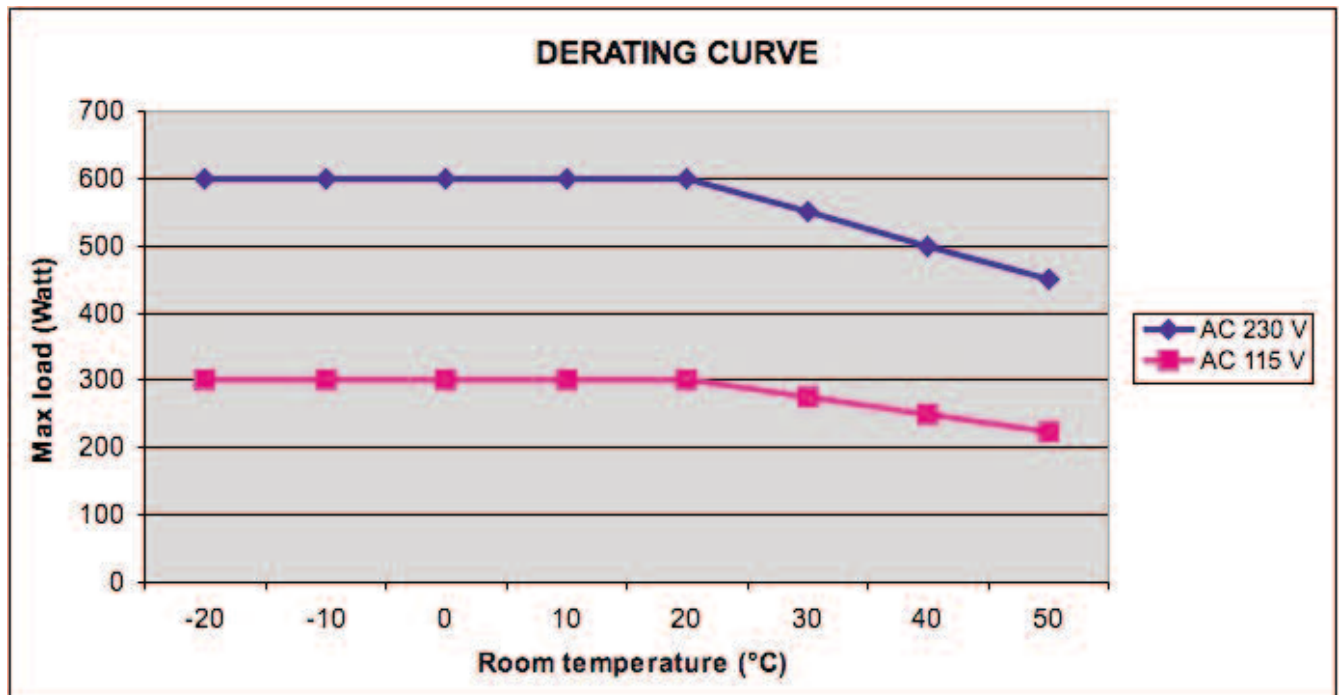

Wiring Diagrams

1-phase load

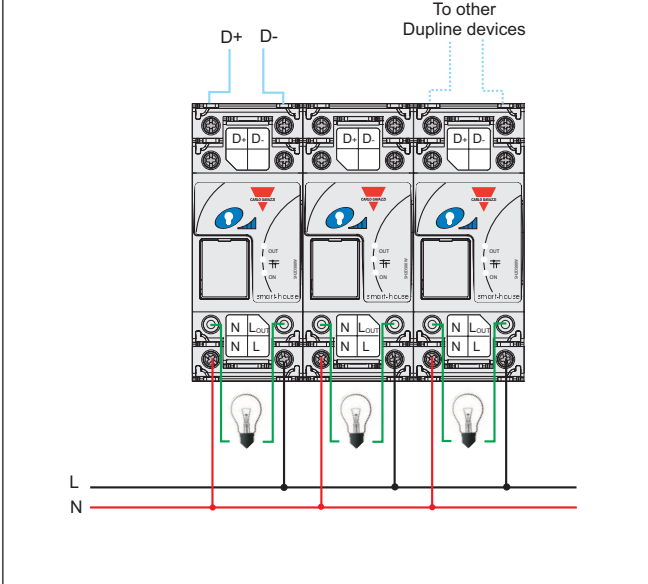

3-phase load

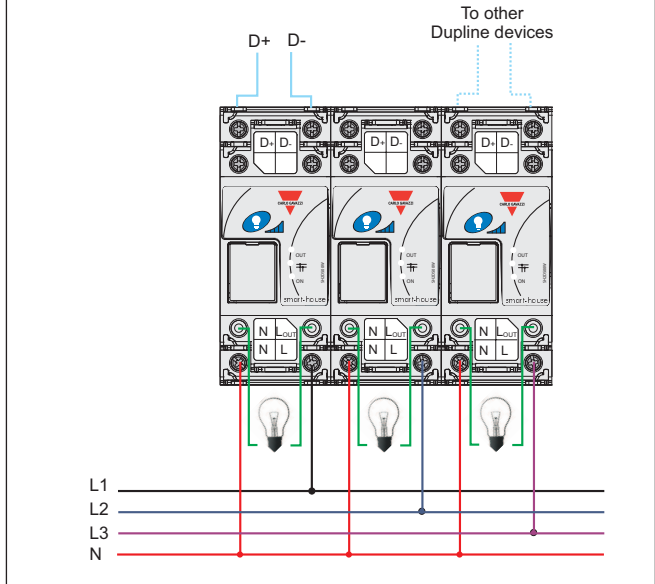

Dimensions

