

Built-in

RGB frames can be cast directly into concrete walls or floors (figures 1 and 2). Alternatively the frames can be cast into a loose section that is built in later. When the demands for fire safety are extremely high, frames can be mounted back-to-back (fig. 3). Such an installation can also be pressure tested.

For there to be sufficient space for the stay plate and compression plate there must be 5 mm of clearance between the frame's inside and the cast hole (fig. 4). MCT Brattberg's expanded polystyrene casting form simplifies fixing when casting and provides the necessary clearance (fig. 5).



Fig. 1



Fig. 2

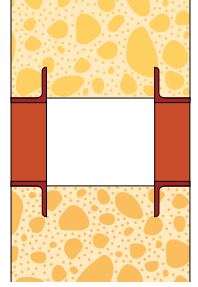

Fig. 3

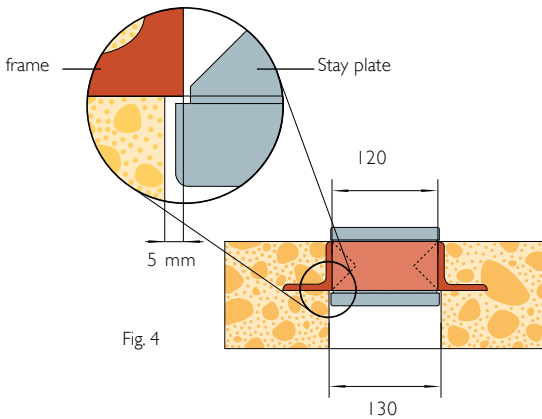
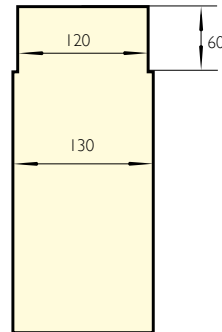

Fig. 4



Polystyrene casting form

Fig. 5



MCT Brattberg's expanded polystyrene casting form.



RGG frames and the flanges of the **Counter frame** are screwed into the wall (fig. 6). A Lycron sealing strip should be used between the wall and the flange to provide a gas tight seal. The galvanised counter frame is available with three different standard depths, which are suitable for the most common wall thicknesses, see below.

RGG and **RGGO** frames can also be bolted in place with the aid of, for example, expansion bolts. A Lycron sealing strip or sealant is used between the frame and the wall to provide a gas tight seal. There are two ways of bolting the frames in position, (figs. 7 and 8). Where practically possible, fig. 7 should always be employed.



Counter frame

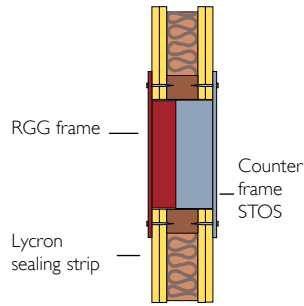

Fig. 6

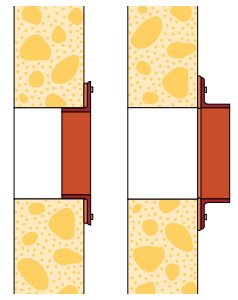

Fig. 7

Fig. 8

| Wall thickness (mm) | | |
|---------------------|-----|-----|
| Counter frame/type | Min | Max |
| 1 | 80 | 110 |
| 2 | 110 | 150 |
| 3 | 150 | 190 |



RGP and **RGPO** frames are installed on one side of the wall when normal demands are made for fire safety, (see fig. 9.) When the safety demands are particularly high two RGP frames are installed back-to-back (fig. 10). RGP can be installed in drilled or cast holes, or in a pipe that is cast in or bolted. Casting is made easier if MCT Brattberg casting forms are used, see picture.

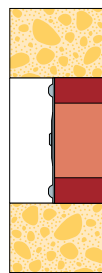

Fig. 9

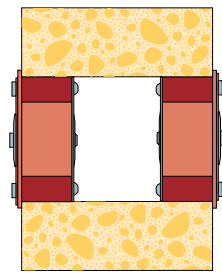

Fig. 10



MCT Brattberg's casting form.