

U.I. Lapp GmbH	<b>PRODUCT INFORMATION</b>	
	<b>SKINTOP® INOX / SKINTOP® INOX-R</b>	07.11.2014

Corrosion-resistant  
Sea water-resistant  
Smooth surfaces - no edges  
Compact design  
Wide, variable clamping ranges



Suitable for outdoor use



Good chemical resistance



Food & Beverage



Wide clamping range



Mechanical resistance



Temperature-resistant



### Info

Stainless steel version with compact design  
For use in the splash zone in the food production

### Application range

Onshore and offshore applications  
Bottling plants and breweries  
Food industry (product-free zone, splash zone)

### Product Make-up

Metric connection thread acc. to EN 50262

### Norm references / Approvals

ECOLAB®  
Industry standard for innovation and efficiency in the field of professional cleaning and disinfection  
DIN EN 1672-2  
Guideline for the design of machinery  
DIN EN ISO 14 159  
Security of machinery – Hygienic requirements  
for the design of machinery

### Note

EMC version is available upon request

Product Management	Document: LAPP_PRO214997EN.pdf	1 / 4
--------------------	--------------------------------	-------

U.I. Lapp GmbH	<b>PRODUCT INFORMATION</b>	
	<b>SKINTOP® INOX / SKINTOP® INOX-R</b>	07.11.2014

**Remark**

Photographs are not to scale and do not represent detailed images of the respective products.

**Technical Data**

Classification:	ETIM 5.0 Class-ID: EC000441 ETIM 5.0 Class-Description: cable screw gland
Material:	Body: Stainless steel - V4A (1.4404 / 316L) Insert: Polyamide Sealing ring: Silicone O-Ring: Silicone
Protection rating:	IP 68 - 10 bar (M12 - M20) IP 68 - 5 bar (M25 - M32) IP 69 K
Temperature range:	-40°C to +100°C

Product Management	Document: LAPP_PRO214997EN.pdf	2 / 4
--------------------	--------------------------------	-------

**SKINTOP® INOX / SKINTOP® INOX-R**

07.11.2014

Part number	Article designation / size	Clamping range ØF (mm)	Thread length/ D (mm)	SW (mm)	Overall length/ C (mm)	Pieces / PU
<b>SKINTOP® INOX</b>						
53806739	12x1,5	4-7	6.5	16	29,3	5
53806740	16x1,5	6-10	7.0	20	32,4	5
53806741	20x1,5	7-13	8.0	24	35,8	5
53806742	25x1,5	9-17	8.0	29	37,8	5
53806743	32x1,5	11-21	9.0	36	43,3	5
<b>SKINTOP® INOX-R</b>						
53806749	12x1,5	3-5	6.5	16	29,3	5
53806750	16x1,5	5-7	7.0	20	32,4	5
53806751	20x1,5	5-10	8.0	24	35,8	5
53806752	25x1,5	7-13	8.0	29	37,8	5
53806753	32x1,5	7-15	9.0	36	43,3	5

U.I. Lapp GmbH	<b>PRODUCT INFORMATION</b>	
	<b>SKINTOP® INOX / SKINTOP® INOX-R</b>	07.11.2014

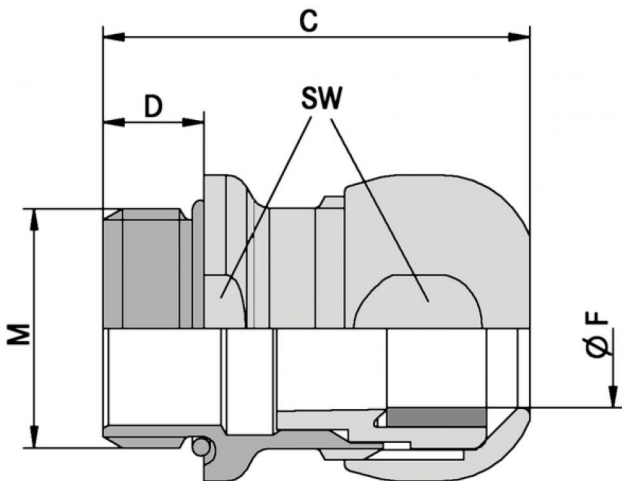

Product Management	Document: LAPP_PRO214997EN.pdf	4 / 4
--------------------	--------------------------------	-------