



Foot switch with metal enclosure

GFS 2Ö/2S

Material number: 1048655 (Material number old: 81203001)

Features/Options:

- With protective guard
- Metal enclosure
- High level of stability
- Low pedal height
- Wiring compartment

Dimensions

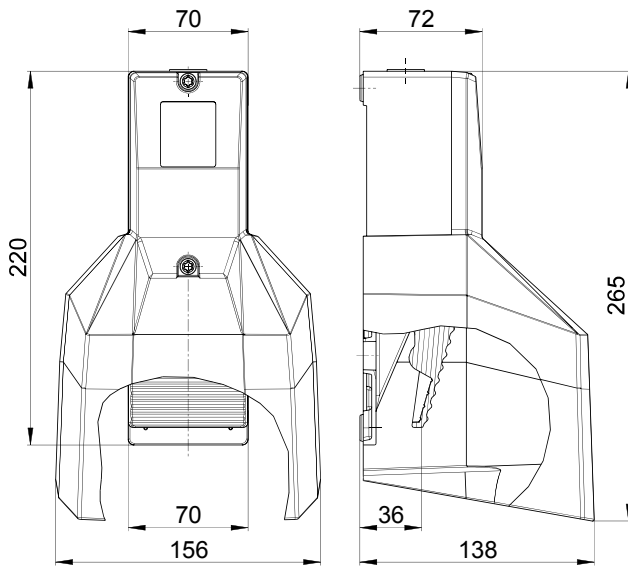

Technical data

Applied standards	EN 60947-5-1
Enclosure	aluminium die-cast, powder-coated
Pedal	thermoplastic, glass-fibre reinforced, impact resistant, self-extinguishing UL 94 V-0
Protective shield	aluminium die-cast, powder-coated
Degree of protection	IP 65 to IEC/EN 60529
B _{10d} (10 % load)	2 million
T _M	max. 20 years
Connection	screw connection terminals
Cable cross-section	max. 2.5 mm ² (incl. conductor ferrules)
Cable entry	1 x M20 x 1.5
Contact material	silver
Switching system	slow action, positive break NC contacts ⊖
Switching elements	2 NC/2 NO contacts, type Zb
Switch insert	2 x ES 40 GF
Utilisation category	AC-15
Rated operating current/voltage I _e /U _e	6 A/400 VAC
Short-circuit protection	6 A gG/gN fuse
Ambient temperature	-25 °C ... +80 °C
Mechanical life	> 1 million operations
Approvals	
Weight	1000 g

Errors and omissions excepted.



Foot switch with metal enclosure
GFS 2Ö/2S

Material number: 1048655 (Material number old: 81203001)

Contact diagram

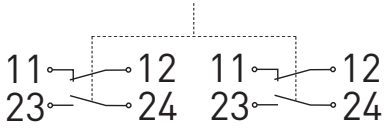

Switching diagram

