

IP20 SELV      

TALEXconverter LCI 15 W 350 mA IP20
TEC series

Product description

- Constant current LED control gear
- Universal input voltage range
- Constant output current 350 mA
- Strain relief
- Screw terminal

Properties

- High efficiency
- Low power loss
- Overtemperature protection
- Overload protection with automatic restart
- Short-circuit shutdown feature with automatic restart
- Protection class 2, SELV
- Casing: polycarbonate, white

Technical data

Rated supply voltage	120 – 240 V
Input voltage AC	108 – 264 V
Input voltage DC	120 – 240 V
Rated current (at 230 V 50 Hz)	0.08 A
Mains frequency	0 / 50 / 60 Hz
Efficiency	> 75 %
Max. input power	17 W
λ (at 230 V 50 Hz)	0.91
Output current tolerance	$\pm 8 \%$
Output current ripple	$\pm 32 \%$
Max. repetitive output peak current	500 mA
Max. non-repetitive output peak current	550 mA
Max. output voltage ^①	48 V
Turn on time (output)	≤ 0.5 s
Turn off time (output)	≤ 1 s
Hold on time at power failure (Output)	10 ms
Ambient temperature t_a	-25 ... +50 °C
Ambient temperature t_a (at life-time 50,000 h)	-25 ... +40 °C
Max. casing temperature t_c	70 °C
Storage temperature	-30 ... +85 °C
Dimensions LxWxH	165 x 43 x 30 mm
Hole spacing D	142 mm

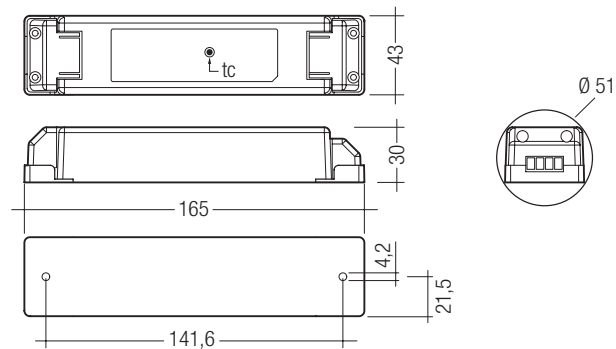

Ordering data

Type	Article number	Packaging carton	Packaging pallet	Weight per pcs.
LCI 015/0350 E020	24166312	40 pc(s).	2,000 pc(s).	0.14 kg

Specific technical data

Type	Output current	Output voltage range
LCI 015/0350 E020	350 mA	21 – 43 V

^① In non-load operation.

Standards

EN 55015
EN 61000-3-2
EN 61000-3-3
EN 61347-1
EN 61347-2-13
EN 61547
EN 62384

Installation instructions

Please note that LCI 015/0350 E020 complies with protection class II so special measures are needed if it is to be installed in protection class I applications / luminaires.

Please note the requirements set out in the document LED_Betriebsgeraete_installationshinweis.pdf (<http://www.tridonic.com/com/de/technische-doku.asp>).

Over temperature protection

Automatic shutdown of the LED control gear if the temperature limit is exceeded.
Automatic restart if the temperature falls below the limit.

Overload protection

Automatic shutdown of the LED control gear if the maximum output voltage is exceeded.
Automatic restart if the output voltage is below the limit.

Glow wire test according to EN 60695-2-11

850 °C passed.

Maximum loading of automatic circuit breakers

Automatic circuit breaker type	C10	C13	C16	C20	B10	B13	B16	B20	Inrush current	
Installation Ø	1.5 mm ²	1.5 mm ²	1.5 mm ²	2.5 mm ²	1.5 mm ²	1.5 mm ²	1.5 mm ²	2.5 mm ²	I _{max}	time
LCI 015/0350 E020	60	90	120	140	30	45	60	70	80A	0.001 ms

Efficiency versus load

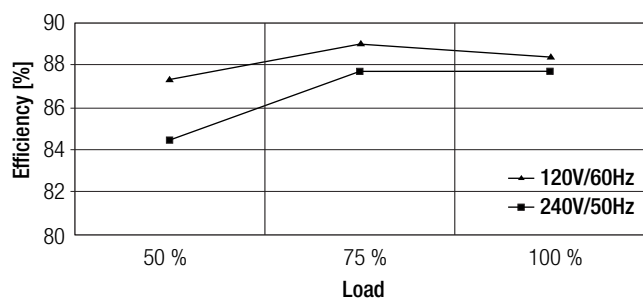

PF value versus load

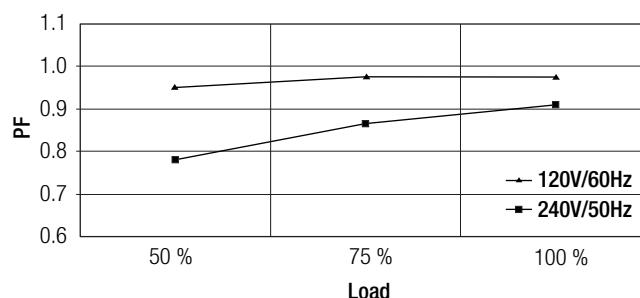

Wiring diagram

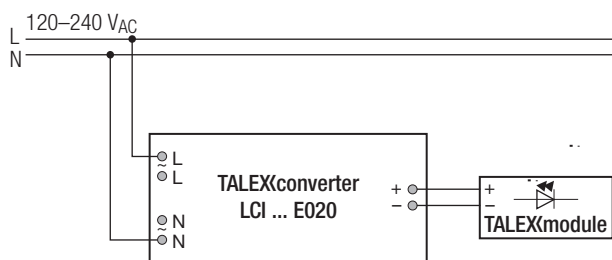

Installation instructions

The switching of LEDs on secondary side is not permitted.

Wiring type and cross section

The wiring can be in stranded wires with ferrules or solid. For perfect function of the screw terminals the strip length should be 7.5–8.5 mm for the terminal.

Input / Output terminal

PRI:

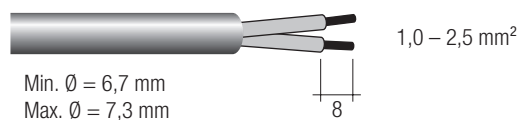

SEC:

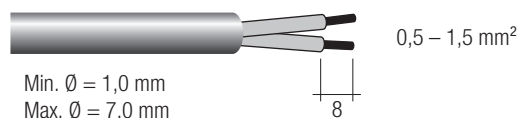

Isolation and electric strength testing of luminaires

Electronic devices can be damaged by high voltage. This has to be considered during the routine testing of the luminaires in production.

According to IEC 60598-1 Annex Q (informative only) or ENEC 303-Annex A, each luminaire should be submitted to an isolation test with 500 V_{DC} for 1 second. This test voltage should be connected between the interconnected phase and neutral terminals and the earth terminal.

The isolation resistance must be at least 2 MΩ.

As an alternative, IEC 60598-1 Annex Q describes a test of the electrical strength with 1500 V_{AC} (or 1.414 x 1500 V_{DC}). To avoid damage to the electronic devices this test must not be conducted.

Additional information

Additional technical information at
www.tridonic.com → Technical Data

Guarantee conditions at
www.tridonic.com → Services

No warranty if device was opened.