

# FREJA

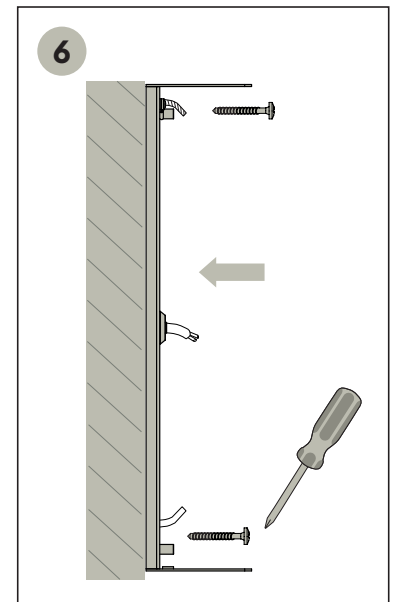

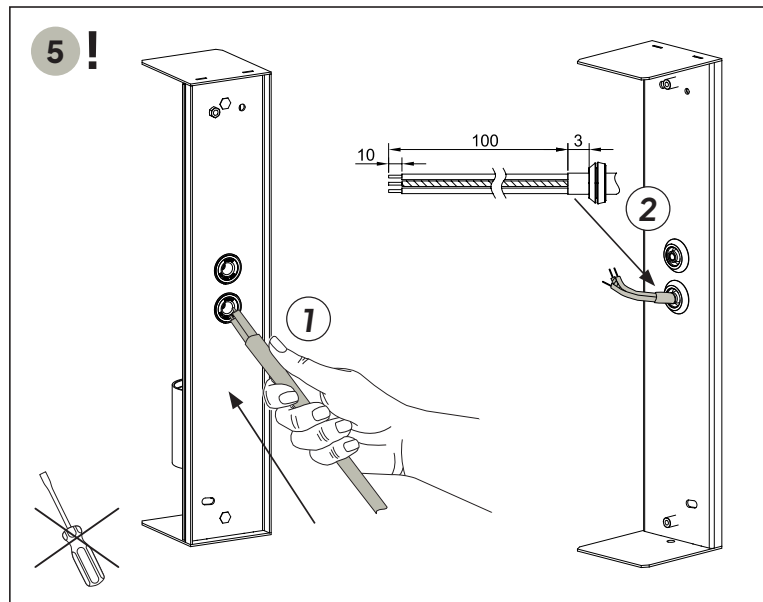

- ENG** Turn off the power before replacing the light source.  
**NOR** Skru av strømmen før skifte av lyskilde.  
**SWE** Koppla bort strömmen innan för byte av ljuskälla sker.  
**DE** Schalten Sie die Stromversorgung aus, bevor Sie die Lichtquelle austauschen.  
**FR** Éteindre le courant avant de remplacer la source lumineuse.  
**PL** Przed wymianą źródła światła należy wyłączyć zasilanie.

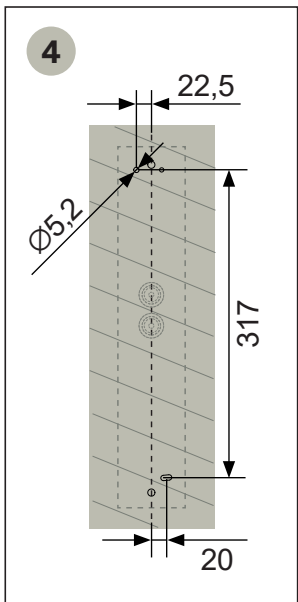
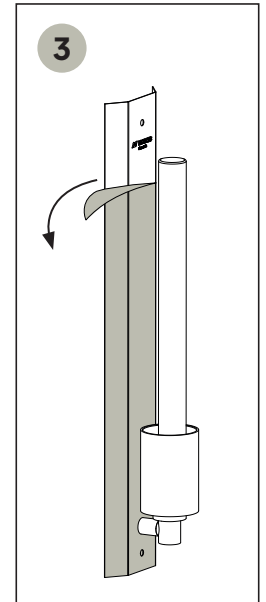
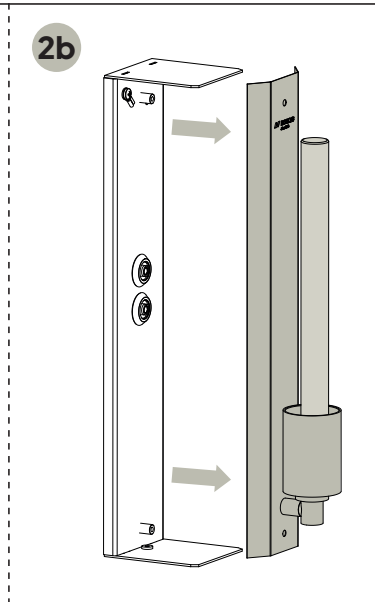
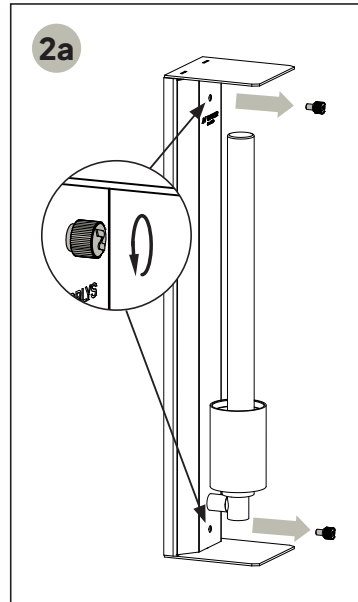
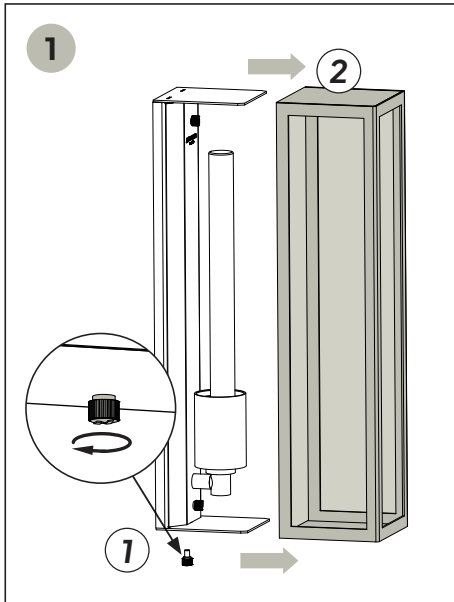
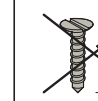
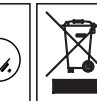
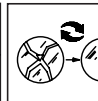
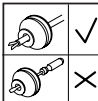
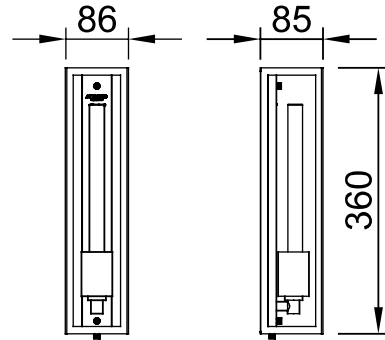
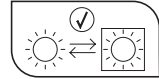
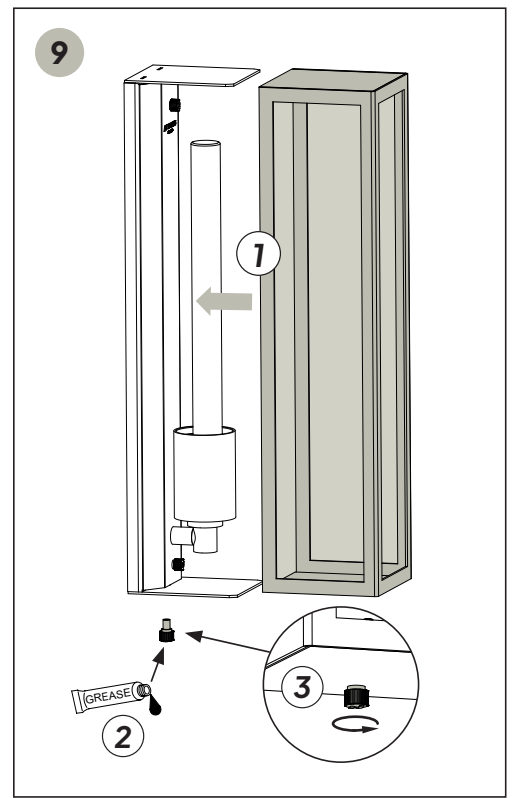
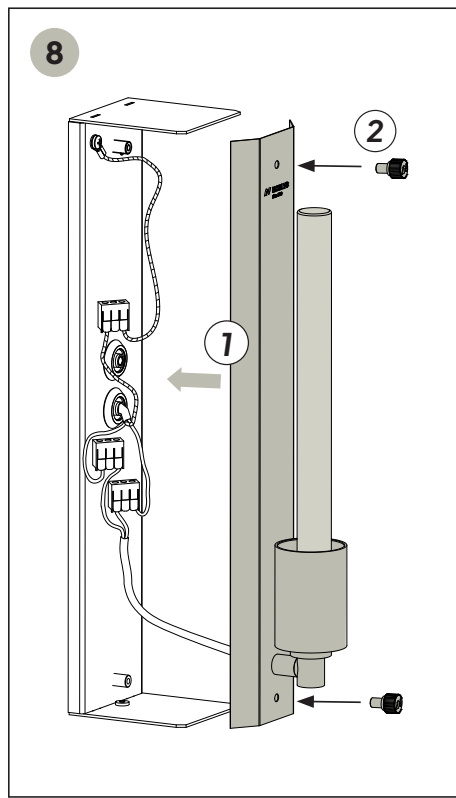
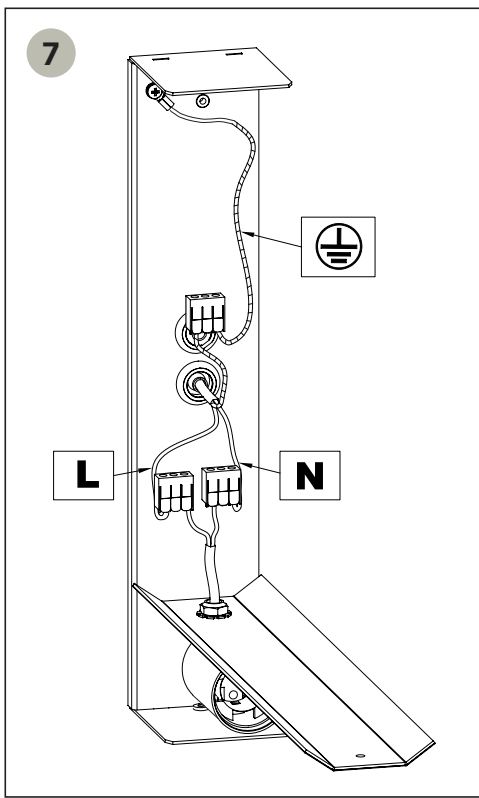

- ENG** Fix the element to the substrate.  
**NOR** Fest elementet til underlaget.  
**SWE** Fäst elementet på underlaget.  
**DE** Befestigen Sie das Element auf dem Untergrund.  
**FR** Fixer l'élément sur son support.  
**PL** Przymocować element do podłoża.



- ENG** Replace any cracked protective screen.  
**NOR** Sprukket glass må skiftes.  
**SWE** Sprucket glas måste bytas.  
**DE** Ersetzen Sie eine beschädigt Schutzschirm.  
**FR** Remplacer les écrans de protection fissurés.  
**PL** Wymienić każdy pęknięty ekran ochronny.



- ENG** Replaceable light source.  
**NOR** Utskiftbar lyskilde.  
**SWE** Utbytbar ljuskälla.  
**DE** Auswechselbare Lichtquelle.  
**FR** Source lumineuse interchangeable.  
**PL** Wymienne źródło światła.



- ENG** The kit does not include ground mounting pins.  
**NOR** Settet inkluderer ikke festepinner til bakken.  
**SWE** Satsen innehåller inte markmonerings kit.  
**DE** Kein Schraubensatz im Lieferumfang enthalten.  
**FR** Livré sans visserie.  
**PL** Zestaw nie zawiera kołków mocujących.



- ENG** Before starting the installation, please read the instructions carefully.  
**NOR** Les bruksanvisningen nøye før du begynner monteringen.  
**SWE** Läs igenom instruktionen noggrant innan du påbörjar monteringen.  
**DE** Lesen Sie die Anleitung vor Beginn der Montage sorgfältig durch.  
**FR** Avant de commencer le montage, veuillez lire attentivement les instructions.  
**PL** Przed rozpoczęciem montażu należy dokładnie zapoznać się z instrukcją.



- ENG** The light source contained in this luminaire shall only be replaced by the manufacturer or his service agent, or a similar qualified person.  
**NOR** Installasjon skal utføres av en autorisert installatør/fagmann.  
**SWE** All installation skall utföras av auktoriserad elinstallatör.  
**DE** Die Montage und der Austausch der in dieser Leuchte enthaltenen Lichtquelle dürfen nur durch den Hersteller oder seinen Kundendienst oder einer gleich qualifizierte Person ausgeführt werden. Bitte lokale Bestimmungen beachten!  
**FR** Le montage et le remplacement de la source lumineuse du luminaire doit être fait uniquement par le fabricant, un agent de maintenance ou une personne ayant des qualification similaires. Merci de respecter la réglementation nationale.  
**PL** Źródło światła zastosowane w tej oprawie oświetleniowej powinno być wymieniane wyłącznie przez producenta lub jego przedstawiciela serwisowego, lub podobnie wykwalifikowaną osobę.



- ENG** Only pierce NORLYS gasket with the installation cable of 7-10,5mm diameter. Damage caused by tools will lead to IP degradation. Wrong installation leads to loss of warranty.  
**NOR** Gjennombor NORLYS-pakning med installasjonskabel  $\varnothing$ 7-10,5 mm diameter. Skader forårsaket av verktøy vil føre til IP-nedbrytning. Feil installasjon fører til tap av garanti.  
**SWE** Använd endast 7-10,5mm  $\varnothing$  kabel för genomträngning av packningar. Skador orsakade av andra typer av verktyg kan sänka IP-klassning på armaturen. Felaktig installation kan orsaka garantiförlust.  
**DE** Nur NORLYS Dichtung mit dem Installationskabel eines Durchmessers von 7-10,5mm durchstechen. Beschädigung durch Werkzeuge führt zu IP Verminderung und Garantieverlust.  
**FR** Percez seulement le joint NORLYS avec le câble d'installation d'un diamètre de 7 à 10,5 mm. Les dommages causés par des outils entraîneront une dégradation de l'IP et la perte de garantie!  
**PL** Uszczelkę NORLYS  $\varnothing$ 7-10,5mm przebijać tylko przewodem instalacyjnym. Przebicie innymi narzędziami powoduje utratę szczelności IP oraz utratę gwarancji.

