

# Produktdatablad

Spesifikasjoner



## Mykstarter, Altivar Soft Starter ATS430, 17A, 208-600V AC, kontrollforsyning 110-230 V AC

ATS430D17S6

EAN: 3606486948606

### Produktdata

Produktspekter	Altivar Soft Starter ATS430
Produkt eller type komponent	Mykstarter
Produsert i	Asynkroner motorer
Produktspesifikk applikasjon	Standard industrial machines
Kortnavn utstyr	ATS430
antall faser i nettverket	3 faser
Driftskategori	AC-3A AC-53A
Ue power supply voltage	208...600 V AC ( - 15...10 %)
power supply frequency	50...60 Hz - 20...20 %
[Ie] nominell driftsstrøm	Normal duty: 17 A in line 40 °C)
Service factor at Ie	100
Torque control	True
IP-grad	IP20
Motoreffekt kW	4 kW på 230 V in line normal duty 7,5 kW på 400 V in line normal duty 7,5 kW på 440 V in line normal duty 9 kW på 500 V in line normal duty 9 kW på 525 V in line normal duty
Motoreffekt hk	3 hp på 208 V normal duty 5 hp på 230 V normal duty 10 hp på 460 V normal duty 15 hp på 575 V normal duty
Kommunikasjonsport protokoll	Modbus serial

### Teknisk data

Tilkopling av utstyr	In line
overbelastningsstrøm	400 % Ie for 13 s
"on-load" -faktor	50 %
Operating cycles/hour	10 cyc/h
[Us] control circuit voltage	110 - 230 V AC 50...60 Hz - 15...10 %
Tilsynelatende effekt	70 VA
Integrated motor overload protection	True
motor thermal protection class	Class 10E

<b>beskyttelsestype</b>	Fase feil: mains Thermal protection: mains Thermal protection: Starter Current overload: Motor Motor underload: Motor Excessive acceleration time: Motor Motor phase loss detection: Motor Protection against line phase inversion: mains External thermal protection: Motor Short-circuit between motor phase and earth: Motor
<b>current limiting %In (5 x Ie maximum)</b>	150...700 %
<b>[In] Rated current pwr loss specifctn</b>	17 A
<b>Power loss static current independent</b>	19 W
<b>Power loss per device current dependent</b>	2 W
<b>Power loss during starting</b>	133 W during starting at 40 °C at 400% In
<b>Standarder</b>	EN/IEC 60947-4-2 UL 60947-4-2 IEC 60664-1
<b>Produktsertifikater</b>	cULus CE UKCA CCC RCM
<b>Merking</b>	CULus CE UKCA CCC RCM
<b>Styrespenning</b>	24 V DC
<b>digital inngangsnummer</b>	4
<b>digital inngangstype</b>	( STOP) digital input, 4.4 kOhm ( RUN) digital input, 4.4 kOhm ( DI3) digital input, 4.4 kOhm ( DI4) digital input, 4.4 kOhm
<b>inngangskompatibilitet</b>	STOP: digital input nivå 1 PLC i samsvar med EN/IEC 61131-2 RUN: digital input nivå 1 PLC i samsvar med EN/IEC 61131-2 DI3: digital input nivå 1 PLC i samsvar med EN/IEC 61131-2 DI4: digital input nivå 1 PLC i samsvar med EN/IEC 61131-2
<b>Diskrét inngangs logikk</b>	Digital input STOP ved Tilstand 0: 0...< 5 V og <= 2 mA ved Tilstand 1: > 11 V, >= 5 mA Digital input RUN ved Tilstand 0: 0...< 5 V og <= 2 mA ved Tilstand 1: > 11 V, >= 5 mA Digital input DI3 ved Tilstand 0: 0...< 5 V og <= 2 mA ved Tilstand 1: > 11 V, >= 5 mA Digital input DI4 ved Tilstand 0: 0...< 5 V og <= 2 mA ved Tilstand 1: > 11 V, >= 5 mA
<b>relé utgang nummer</b>	2
<b>reléutgangstype</b>	Reléutganger R1A, R1C Nei Reléutganger R1B, R1C NC Reléutganger R2A, R2C Nei
<b>minimum brytestrøm</b>	100 mA på 12 V DC for reléutganger
<b>Maximum svitsjestrøm</b>	Reléutganger 2 A / 250 V AC for AC-15 100000 sykluser following IEC 60947-5-1 Reléutganger 2 A / 30 V DC for DC-13 150000 sykluser following IEC 60947-5-1
<b>Antall analoge innganger</b>	1
<b>analogue input type</b>	PTC1 : PTC temperature probe PTC2 : PTC temperature probe
<b>analog utgangsnummer</b>	1
<b>analog utgangstype</b>	Utgangsstrøm AQ1 : 0...20 mA/4...20 mA , impedance< 500 Ohm Spenningsutgang AQ1 : 0...10 V , impedance> 470 Ohm

<b>kommunikasjonsport protokoll</b>	Modbus serial RJ45 Modbus serial open style (DO, D1, PE, COM)
<b>Tilkoblingstype</b>	1 RJ45 Open style
<b>Fysisk interface</b>	2-tråds RS 485 - konntektor(er): RJ45 2-tråds RS 485 - konntektor(er): open style (DO, D1, PE, COM)
<b>ramme for overføring</b>	RTU : 1 RJ45 RTU : open style (DO, D1, PE, COM)
<b>overføringshastighet</b>	4.8...38.4 kbps for modbus serial RJ45 0.3...115.2 kbps for modbus serial open style (DO, D1, PE, COM)
<b>dataformat</b>	8 bits, odd, even or no parity, 1 or 2 bits to stop for modbus serial RJ45 8 bits, konfigurert Odd, selv eller ingen paritet for modbus serial open style (DO, D1, PE, COM)
<b>Antall adresser</b>	0...247 for modbus serial
<b>Tilgangsmetode</b>	Slave modbus serial
<b>Polarisasjonstype</b>	Ingen impedans for modbus serial
<b>Display screen available</b>	True
<b>driftsposisjon</b>	Vertikal +/- 10 grader
<b>Høyde</b>	273 mm
<b>Bredde</b>	130 mm
<b>Dybde</b>	169 mm
<b>Vekt</b>	2,90 kg
<b>internal bypass</b>	True
<b>Mulige funksjoner</b>	Single direction Pre-heating Power monitoring Condition monitoring User management Ports and services hardening Security event logging Cybersecure firmware update Small motor test
<b>material declaration</b>	True

## Miljø

<b>elektromagnetisk kompatibilitet</b>	Strålt og ledet elektromagnetisme nivå A conforming to IEC 60947-4-2 Dempede oscillerende bølger nivå 3 conforming to IEC 61000-4-18 Elektrostatisk utlading nivå 3 conforming to IEC 61000-4-2 Immunitet til elektriske overgangsspenninger nivå 4 conforming to IEC 61000-4-4 Immunitet til rettet radioelektrisk interferens nivå 3 conforming to IEC 61000-4-3 Spennings/strømpuls nivå 3 conforming to IEC 61000-4-5 Immunity to conducted disturbances radio-frequency nivå 3 conforming to IEC 61000-4-6
<b>Forurensninggrad</b>	Nivå 3
<b>[Uimp] nominell impulsspenning</b>	6 kV
<b>[Ui] isolasjonsspenning</b>	600 V
<b>miljøklasse (under drift)</b>	Class 3C3 according to IEC 60721-3-3 Class 3S3 according to IEC 60721-3-3
<b>omgivelsestemperatur for drift</b>	-25...40 °C (uten lastreduksjon) 40...60 °C (with current derating of 1 % per °C above 40 °C)
<b>Omgivelsestemperatur for lagring</b>	-40...70 °C
<b>omgivningens lufttransportstemperatur</b>	-40...70 °C

<b>driftshøyde</b>	<= 2000 m uten lastreduksjon > 2000...4800 m with current derating 1 % per 100 m above 2000 m
<b>relativ fuktighet</b>	5...95 % uten kondensering eller dryppvann i samsvar med EN/IEC 60068-2-3
<b>Maximum deflection under vibratory load (during operation)</b>	1.5 mm at 2...13 Hz
<b>Maximum deflection under vibratory load (during storage)</b>	1.75 mm at 2...9 Hz
<b>Maximum deflection under vibratory load (during transport)</b>	1.75 mm at 2...9 Hz
<b>Maximum acceleration under vibrational stress (during operation)</b>	1 gn at 13...200 Hz
<b>Maximum acceleration under vibratory load (during storage)</b>	1 gn at 9...200 Hz 1.5 gn at 200...500 Hz
<b>Maximum acceleration under vibratory load (during transport)</b>	1 gn at 9...200 Hz 1.5 gn at 200...500 Hz
<b>Maximum acceleration under shock impact (during operation)</b>	15 gn at 11 ms
<b>Maximum acceleration under shock load (during storage)</b>	10 gn at 11 ms
<b>Maximum acceleration under shock load (during transport)</b>	10 gn at 11 ms

## Forpakkingsinformasjon

<b>Enhetsstype pakke 1</b>	PCE
<b>Antall enheter i pakke 1</b>	1
<b>Pakke 1 Høyde</b>	22,500 cm
<b>Pakke 1 Bredde</b>	24,000 cm
<b>Pakke 1 Vekt</b>	34,500 cm
<b>Package 1 Weight</b>	4,018 kg
<b>Enhetsstype pakke 2</b>	S06
<b>Antall enheter i pakke 2</b>	10
<b>Pakke 2 Høyde</b>	75,000 cm
<b>Pakke 2 Bredde</b>	60,000 cm
<b>Pakke 2 Lengde</b>	80,000 cm
<b>Pakke 2 Vekt</b>	48,600 kg

## Garantiperiode

<b>Garanti</b>	18 måneder
----------------	------------

## Environmental Data

Schneider Electric tar sikte på å oppnå Net Zero-status innen 2050 gjennom partnerskap med leverandørkjeden, materialer med lavere slagkraft og sirkularitet via vår pågående "Use Better, Use Longer, Use Again"-kampanje for å forlenge produktlevetiden og resirkulerbarheten.

[Environmental Data forklart >](#)

[Hvordan vi vurderer produktets bærekraft >](#)

### Miljøfotavtrykk

Karbonavtrykk (kg CO2 ekv.) 2139

Miljøinformasjon [Produktmiljøprofil](#)

### Use Better

#### Materialer og emballasje

Emballasje med resirkulert papp Nei

Emballasje uten plast Nei

[EUs RoHS-direktiv](#) Oppfyller kravene med unntak

SCIP-nummer 6d50853e-11c9-49b4-b4cf-9b6edb1894b1

REACH-forordningen [REACH-erklæring](#)

### Use Again

#### Ompakking og reproduksjon

Sirkularitetsprofil [Informasjon om levetidsslutt](#)

WEEE  Produktets avhending må skje i overensstemmelse med EUs avfallsforskrifter, og produktet skal aldri deponeres i restavfallsstrømmen.

Tilbaketakning No

Dimensions Drawings

Dimensions

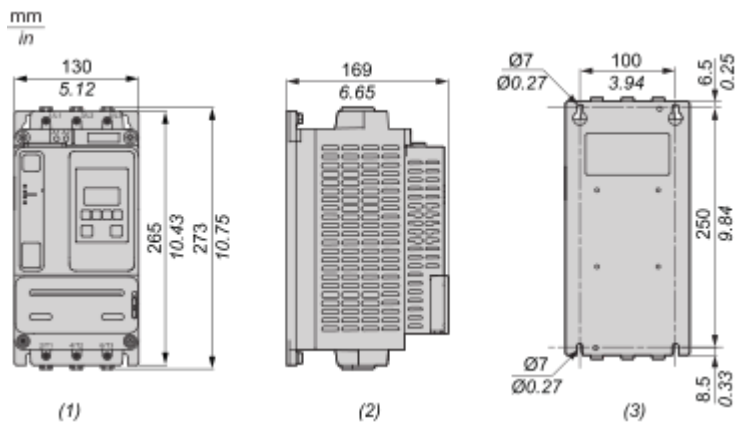

- (1) : Front
- (2) : Side
- (3) : Rear

Mounting and Clearance

Mounting Position

The soft starter is designed to be mounted inside cabinets vertically at  $\pm 10^\circ$  for cooling purposes. Respect the minimum clearances so that the cooling air can circulate from the bottom to the top of the soft starter. The minimum clearances apply to any device close to the soft starter such as circuit breakers, fuses and contactors. Do not install the soft starter above heating elements.

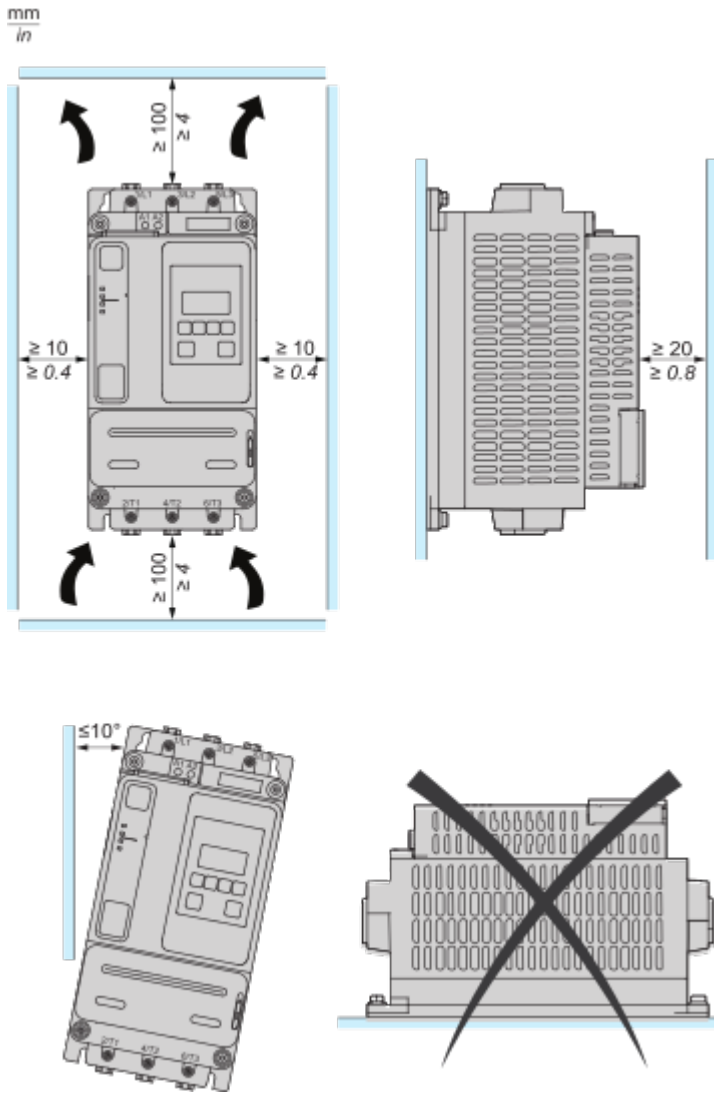

Connections and Schema

Wiring

Wiring the Power Part

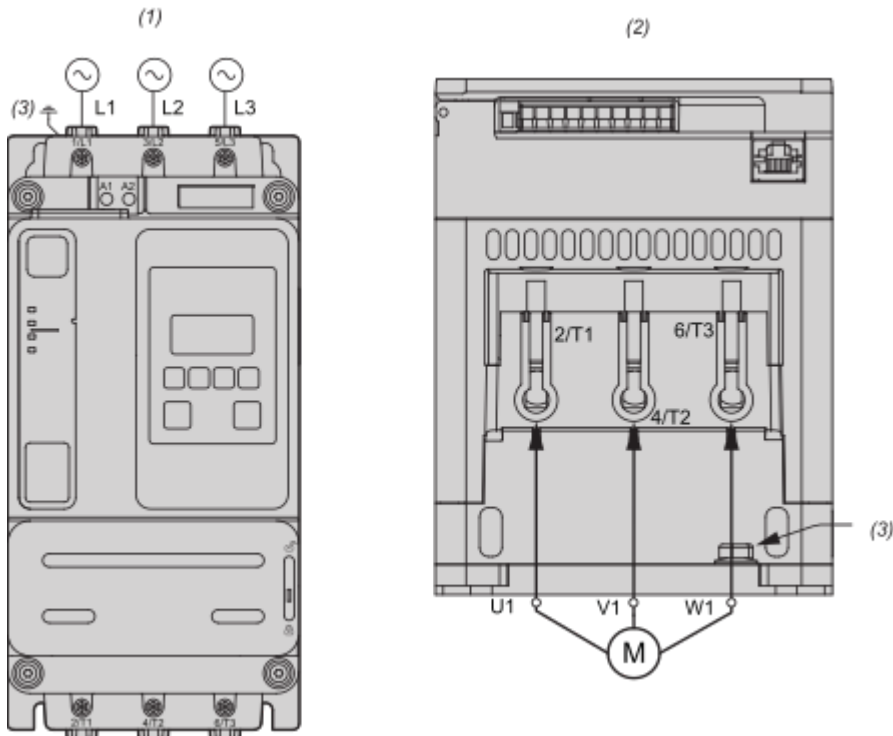

Use class C cables for the power connections.

1/L1, 3/L2, 5/L3 : Mains supply inputs

2/T1, 4/T2, 6/T3 : Outputs to motor

(1) : Mains side

(2) : Motor side (bottom)

(3) : Ground connection

**Connection In Line, With Line Contactor, Type 1 or 2 Coordination, 2-wire control or 3-wire control**

Line contactor controlled based on RUN & STOP or on detected error.

Use relay output R1 set to [Mains Contactor]

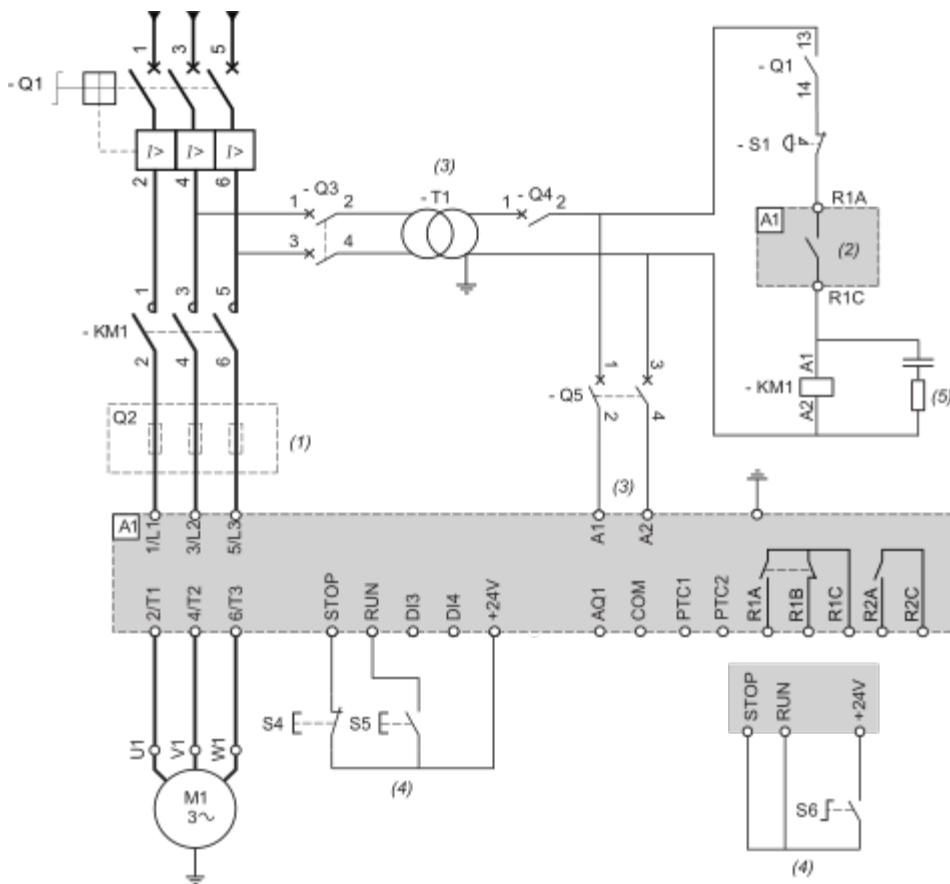

- (1) : Installation of additional fast-acting fuses is mandatory to upgrade to type 2 coordination according to IEC 60947-4-2.
- (2) : Take into account the electrical characteristics of the relays.
- (3) : The transformer must supply 110...230 Vac -15%...+10%, 50/60Hz.
- (4) : 3-wire control or 2-wire control.
- (5) : Select the appropriate voltage surge suppressor.

Designation	Component	Description
Q1	Circuit breaker	Short circuit protection device for the motor
Q2	Circuit breaker	Short circuit protection device for the primary of the transformer
Q3	Fast acting fuses	Short circuit protection device of the soft starter to be used only when type 2 coordination according to IEC 60947-4-2 is required
Q4	Circuit breaker	Short circuit protection device for the secondary of the transformer
Q5	Circuit breaker	Short circuit protection device for the control part of the soft starter
KM1	Contactor	Line contactor
S1	Emergency Stop push-button	Emergency Stop to de-energized KM1 line contactor
S4	Normally close contact push-button	STOP command for 3-wire control

S5	Normally open contact push-button	RUN command for 3-wire control
S6	Selector switch, 2 positions, stay-put, normally open contact	RUN/STOP. command for 2-wire control

**Connection In Line, With Line Contactor, Type 1 or 2 Coordination, 2-wire or 3-wire**

Line contactor controlled by Power ON and Power OFF push-buttons or detected error.

Use relay output R1 set to [Operating State Fault] (factory setting)

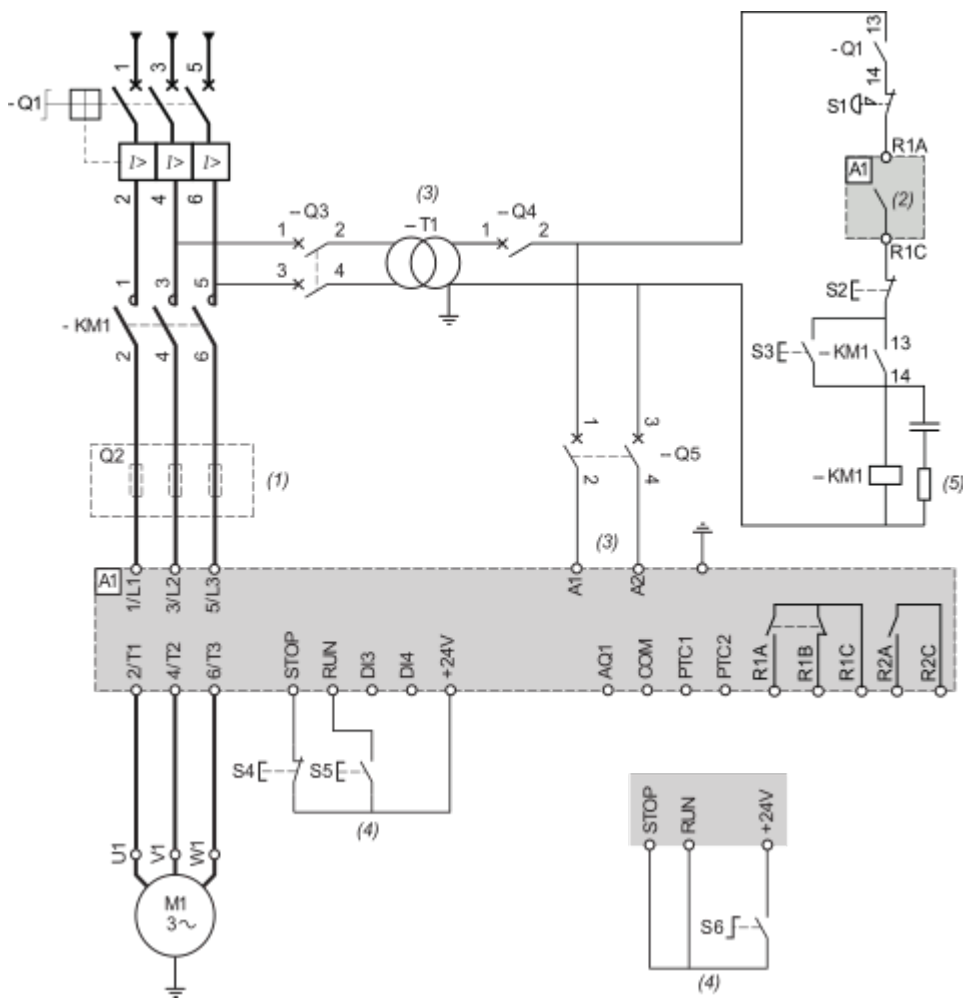

- (1) : Installation of additional fast-acting fuses is mandatory to upgrade to type 2 coordination according to IEC 60947-4-2.
- (2) : Take into account the electrical characteristics of the relays.
- (3) : The transformer must supply 110...230 Vac -15%...+10%, 50/60Hz.
- (4) : 3-wire control and 2-wire control.
- (5) : Select the appropriate voltage surge suppressor.

Designation	Component	Description
Q1	Circuit breaker	Short circuit protection device for the motor
Q2	Circuit breaker	Short circuit protection device for the primary of the transformer
Q3	Fast acting fuses	Short circuit protection device of the soft starter to be used only when type 2 coordination

Q4	Circuit breaker	Short circuit protection device for the secondary of the transformer
Q5	Circuit breaker	Short circuit protection device for the control part of the soft starter
KM1	Contactora	Line contactora
S1	Emergency Stop push-button	Emergency Stop to de-energized KM1 line contactora
S2	Normally close push-button	Power OFF
S3	Normally open push-button	Power ON
S4	Normally close contact push-button	STOP command for 3-wire control
S5	Normally open contact push-button	RUN command for 3-wire control
S6	Selector switch, 2 positions, stay-put, normally open contact	RUN/STOP command for 2-wire control

Control Block Wiring Diagram

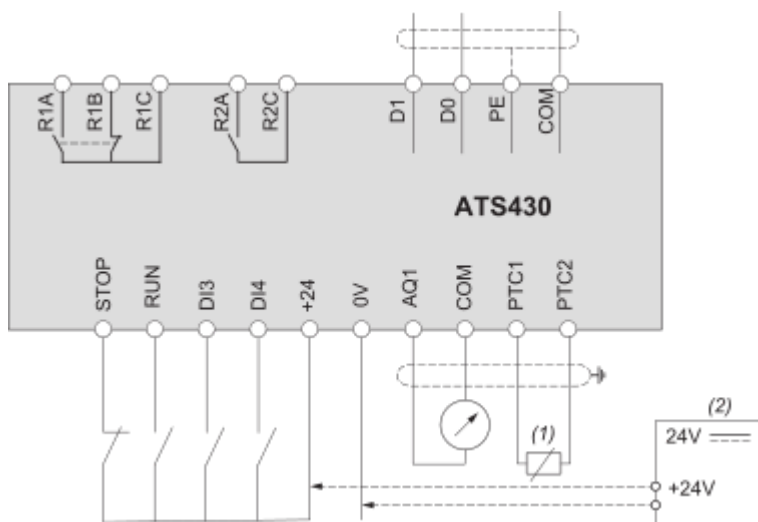

- R1A, R1B, R1C : Programmable relay R1
- R2A, R2C : Relay assigned to End of starting
- STOP, RUN, DI3, DI4 : Digital inputs
- AQ1: Analogue output
- PTC1, PTC2 : PTC connection
- D0, D1 : Serial link based on 2-wire Modbus over serial line electrical interface
- (1) : 2 wire PTC
- (2) : Optional, in case of +24 External Supply usage