

article#	514-9
article description	CEE-wall mounted plug 16A 4p 9h IP44
description long	CEE-wall mounted plug 16A 4p 9h IP44 housing material: PA6 rated current: 16A number of poles: 4 (3P+PE) clock-position: 9h rated voltage/frequency: 200-250V~ / 50+60Hz contacts: brass connection technology: screw terminals IP protection class: IP44
GTIN (EAN)	9003399058363
country of origin	AT
customs number	85366990
net weight	0.188 kg
packaging quantity	10
minimum order quantity	10

ETIM 9.0	EC001319
IEC-amperage	16 A
Voltage according to EN 60309-2	200-250 V (50+60 Hz) blue
Number of poles	4
Clock hour position	9 h
Identification colour	Blue
Degree of protection (IP)	IP44
Connection system	Screwed terminal
Construction type	Surface mounted device plug
Phase inverter	False
Angle of plug	Angled
Material	Plastic
Contact material	CuZn
Surface treatment contacts	Untreated

a	121 mm
b	76 mm
wire flexible	1-2,5 mm ²
wire solid	1-4 mm ²
contact screws	100 Ncm
housing screws	110 Ncm
connecting screws	110 Ncm
dismantling length	50 mm
stripping length	10-12 mm
ambient temperature	-25 – 40 °C
temperature resistance	-25 – 80 °C

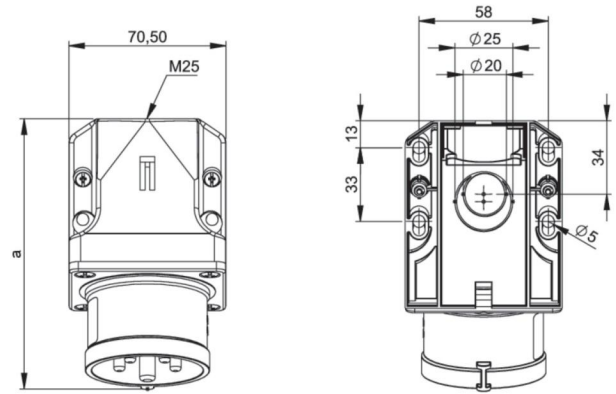

b=Höhe/height
Neigung/angle=15°



<https://www.pcelectric.at/shop/en/?func=detail&artnr=514-9>